



## 48" Sealed Burner Rangetops

The patented, dual-stacked sealed gas burners of our new sealed burner rangetop take control to a new level. Two levels, really. The upper-tier burner delivers maximum heat transfer at higher settings; the lower-tier continuous flame ably handles the subtleties of simmering and melting. The Wolf exclusive infrared charbroiler, infrared griddle and French top ensure this rangetop stands out from the rest in performance and also beauty. Available in natural or LP gas.



Model SRT484F shown.



Model SRT486C



Model SRT486G



Model SRT484CG



Model SRT484DG



Model SRT484F

### FEATURES

- Stainless steel exterior finish with island trim included.
- Optional infrared charbroiler, infrared griddle, double griddle and French top configurations.
- Distinctive red control knobs—black knobs optional.
- Platinum bezels surround all knobs—chrome or brass bezels optional.
- Dual-stacked, sealed burners, all with simmer capabilities and automatic reignition at all settings.
- Melt feature on 9,200 Btu burner.
- Porcelain-coated cast iron continuous grates.

### SURFACE FEATURES

Model	SRT486C	SRT486G	SRT484CG	SRT484DG	SRT484F
Surface Burners					
15,000 Btu high / 950 Btu simmer	5	5	3	3	3
Surface Burner					
9,200 Btu high / 325 Btu simmer	1	1	1	1	1
Infrared Charbroiler – 16,000 Btu	•		•		
Infrared Griddle – 15,000 Btu		•	•		
Double Griddle – 15,000 Btu (2)				•	
French Top – 15,000 Btu					•

Model numbers are for natural gas sealed burner rangetops, add (-LP) to the model number for LP gas.

### ACCESSORIES

- Stainless steel risers in 5" and 10", or 20" riser with shelf.
- Black control knobs.
- Chrome or brass bezels.
- Porcelain-cast wok grate and single burner grate.
- Porcelain-cast two-burner S-grate.
- Hardwood cutting board (griddle models only).
- Griddle cleaning kit.



This appliance is certified by Star-K to meet strict religious regulations in conjunction with specific instructions found on [www.star-k.org](http://www.star-k.org).



Dual-stacked sealed burner.

Accessories are available through your authorized Wolf dealer. For local dealer information, visit the [find a showroom section of our website](http://find_a_showroom_section_of_our_website), [wolfappliance.com](http://wolfappliance.com).



## 48" Sealed Burner Rangetops

### OVERALL DIMENSIONS

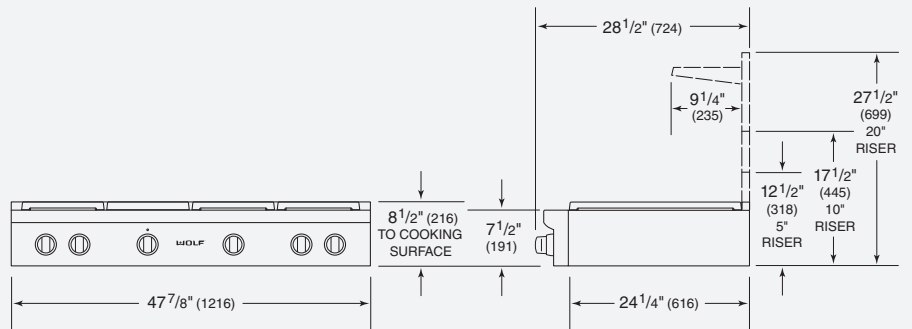

Unit dimensions may vary by  $\pm 1/8$ ".

### SPECIFICATIONS

Exterior Finish	Stainless Steel
Overall Width	47 7/8"
Overall Height (to cooking surface)	8 1/2"
Overall Depth	28 1/2"
Opening Width	48"
Opening Height (to countertop)	7 1/2"
Opening Depth	24"
Electrical Requirements	110/120 V AC 50/60 Hz, 15 amp circuit
Power Cord	6' cord with grounded plug
Shipping Weight	240–280 lbs

### INSTALLATION SPECIFICATIONS

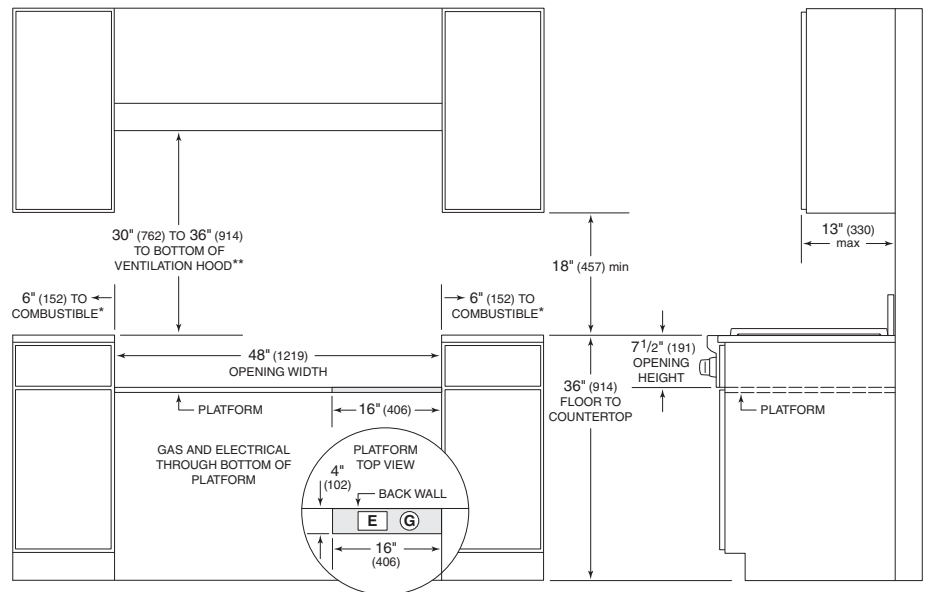

\*Minimum clearance from rough opening to combustible materials up to 18" (457) above countertop.

\*\*36" (914) minimum clearance, 44" (1118) for charbroiler, from countertop to combustible materials without ventilation hood.

NOTE: For island installations, 12" (305) minimum clearance from back of rangetop to combustible rear wall above countertop.

### INSTALLATION NOTES

- A riser is required for installations against a combustible surface.
- A Wolf pro wall, chimney, island ventilation hood or hood liner is recommended.
- For LP gas installations above 8,600' a high altitude conversion kit is required. For natural gas installations above 10,250', contact your authorized Wolf dealer.

Dimensions in parentheses are in millimeters unless otherwise specified.