

USE & CARE GUIDE

Cooktop Low-Profile Ventilation Hoods



Contents

Wolf Cooktop Low-Profile Ventilation Hoods	3
Safety Instructions	4
Cooktop Low-Profile Hood Features	6
Cooktop Low-Profile Hood Operation	8
Cooktop Low-Profile Hood Care	9
Troubleshooting Guide	13
Service Information	14
Wolf Warranty	15

Features and specifications are subject to change at any time without notice. Visit our website, wolfappliance.com for the most up-to-date information.

IMPORTANT NOTE: Throughout this guide, dimensions in parentheses are millimeters unless otherwise specified.

Important Note

To ensure the safe and efficient use of Wolf equipment, please take note of the following types of highlighted information throughout this guide:

IMPORTANT NOTE highlights information that is especially important.

CAUTION signals a situation where minor injury or product damage may occur if instructions are not followed.

WARNING states a hazard that may cause serious injury or death if precautions are not followed.



Thank You

Your purchase of a Wolf cooktop low-profile hood attests to the importance you place upon the quality and performance of your cooking equipment. We understand this importance and have designed and built your ventilation hood with quality materials and workmanship to give you years of dependable service.

Before you begin using your ventilation hood, please take some time to read this use & care guide. It will be to your benefit to familiarize yourself with the safety practices, features, operation and care recommendations for your ventilation hood.

Your Wolf ventilation hood is protected by a warranty that is one of the finest in the industry. Take a moment to read the warranty statement at the end of this guide and refer to it should service become necessary.

If service should become necessary, you will need the model and serial numbers of the cooktop low-profile hood. Both numbers are listed on the product rating plate, located on the underside of the hood, above the grease filter. The filter must be removed to access the rating plate. Refer to the illustration below.

IMPORTANT NOTE: Wolf cooktop low-profile hoods are recommended for use with Wolf induction, electric and gas cooktops and integrated modules. For ranges and rangetops, a Wolf pro ventilation hood is recommended.

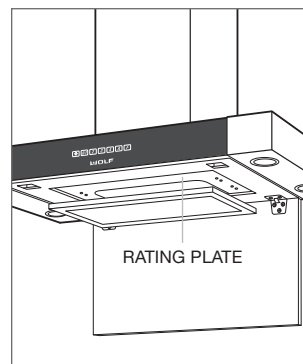

Location of rating plate.

IMPORTANT INSTRUCTIONS

IMPORTANT NOTE: Read all safety instructions before using this appliance.

- Read this use & care guide carefully before using your new ventilation hood to reduce the risk of fire, electric shock or injury to persons.
- Ensure proper installation and servicing. This appliance must be properly installed and grounded by a qualified technician.
- Warranty service must be performed by a Wolf authorized service center.
- Installation work and electrical wiring must be done by qualified person(s) in accordance with all applicable codes and standards, including fire-rated construction codes and standards.
- Use the ventilation hood only in the manner intended by Wolf Appliance, Inc. If you have questions, contact us at 800-332-9513.
- Before servicing or cleaning, switch power off at the service panel and lock the service disconnecting means to prevent power from being switched on accidentally. When the service disconnecting means can not be locked, securely fasten a prominent warning device, such as a tag, to the service panel.
- Sufficient air is needed for proper combustion and exhausting of gases through the flue (chimney) of fuel burning equipment to prevent back drafting.
- Follow the heating equipment manufacturer's guideline and safety standards such as those published by the National Fire Protection Association (NFPA), the American Society for Heating, Refrigeration and Air Conditioning Engineers (ASHRAE) and the local code authorities.

GENERAL SAFETY REQUIREMENTS

- For general ventilating use only. Do not use this ventilation hood to exhaust hazardous or explosive materials and vapors.
- For best capture of cooking impurities, the bottom of the hood should be a minimum of 30" (762) and a maximum of 36" (914) above the countertop.
- Ducted fans must always be vented to the outdoors.
- To reduce the risk of fire, use only metal ductwork.
- To reduce the risk of fire or electric shock, do not use this fan with any solid-state speed control device.
- Use only with ventilation hood cord connection kits that have been investigated and found acceptable for use with this model hood.
- When cutting or drilling into wall or ceiling, do not damage electrical wiring or other hidden utilities.

⚠ CAUTION

To reduce the risk of fire and to properly exhaust air, always duct air outside. Do not vent exhaust air into spaces within walls or ceilings or into attics, crawl spaces or garages.

⚠ CAUTION

To reduce the risk of injury, disconnect the power supply before servicing. This hood is equipped with an integral disconnecting switch located inside the blower housing. Refer to page 13.

IMPORTANT INSTRUCTIONS

GENERAL SAFETY REQUIREMENTS

- Do not repair or replace any part of this appliance unless specifically recommended in this guide. All other service should be performed by a qualified technician.
- This ventilation hood is equipped with a thermostat which may start the blower automatically. To reduce the risk of injury and to prevent power from being switched on accidentally, switch power off at service panel and lock or tag service panel.
- Avoid using food products that produce flames under the ventilation hood.
- This product may have sharp edges. Be careful to avoid cuts and abrasions during installation and cleaning.

⚠ WARNING

TO REDUCE RISK OF COOKTOP GREASE FIRE:

- A) Never leave surface units unattended at high settings. Boilovers cause smoking and greasy spillovers that may ignite. Heat oils slowly on low or medium settings.
- B) Always turn hood on when cooking at high heat or when flambeing foods (i.e. Crepes Suzette, Cherries Jubilee, Peppercorn Beef Flambé).
- C) Clean ventilating fans frequently. Grease should not be allowed to accumulate on fan or filter.
- D) Use proper pan size. Always use cookware appropriate for the size of the surface element.

TO REDUCE THE RISK OF INJURY TO PERSONS IN THE EVENT OF A COOKTOP GREASE FIRE, OBSERVE THE FOLLOWING:

- Smother flames with close-fitting lid, cookie sheet, or metal tray, then turn off the burner. Be careful to prevent burns. If the flames do not go out immediately, evacuate and call the fire department.
- Never pick up a flaming pan—you may be burned.
- Do not use water, including wet dishcloths or towels—a violent steam explosion will result.

USE AN EXTINGUISHER ONLY IF:

- You know you have a class ABC extinguisher and you already know how to operate it.
- The fire is small and contained in the area where it started.
- The fire department is being called.
- You can fight the fire with your back to an exit (NFPA fire safety tips).

Low-Profile Wall Hood Features

- Heavy-duty, stainless steel seamless construction.
- 500 CFM internal blower included with (I) models.
- In-line or remote blower options for models CTEWH36 and CTEWH45.
- Telescopic flue fits 8' to 9' ceilings.
- Front-mounted electronic controls with digital indicator and four-speed blower control.
- Heat sentry to automatically turn unit on when heat is sensed and to adjust blower speed.
- Halogen lighting with three settings.
- Delay-off feature to automatically turn unit off.
- Filter clean indicator.
- Stainless steel filter cover(s) with dishwasher-safe aluminum mesh filter(s).
- Transition with backdraft damper.
- UL listed to US and Canadian safety standards.
- Two and five year residential warranty.

COOKTOP LOW-PROFILE WALL HOOD

Model CTEWH36 shown.

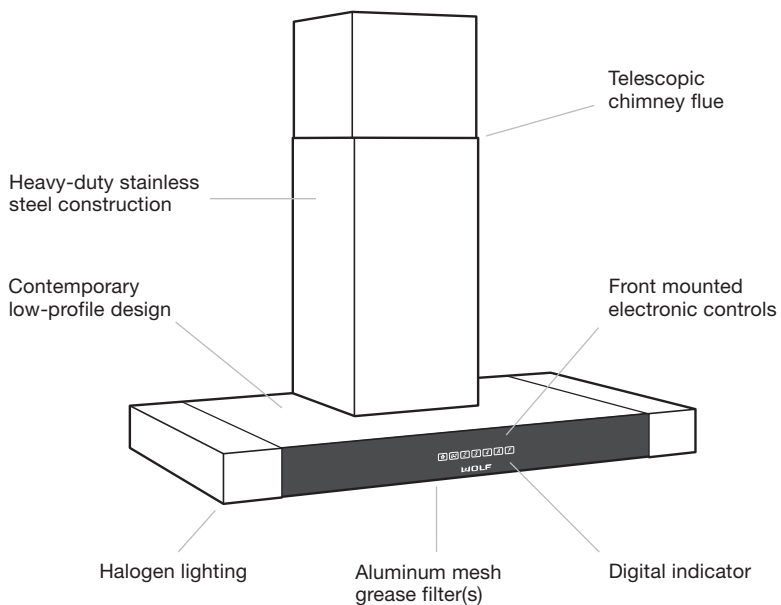

Low-Profile Island Hood Features

- Heavy-duty, stainless steel seamless construction.
- 500 CFM internal blower included.
- Telescopic flue fits 8' to 9' ceilings.
- Front-mounted electronic controls with digital indicator and four-speed blower control.
- Heat sentry to automatically turn unit on when heat is sensed and to adjust blower speed.
- Halogen lighting with three settings.
- Delay-off feature to automatically turn unit off.
- Filter clean indicator.
- Stainless steel filter covers with dishwasher-safe aluminum mesh filters.
- Transition with backdraft damper.
- UL listed to US and Canadian safety standards.
- Two and five year residential warranty.

Optional Accessories

Optional accessories are available through your Wolf dealer. To obtain local dealer information, visit the locator section of our website, wolfappliance.com.

- In-line and remote blowers for wall hood models CTEWH36 and CTEWH45.
- 30" high stainless steel wall shield for wall hoods.
- Recirculating kit and filter for non-ducted applications (internal blower models).

COOKTOP LOW-PROFILE ISLAND HOOD

Model CTEIH42I shown.

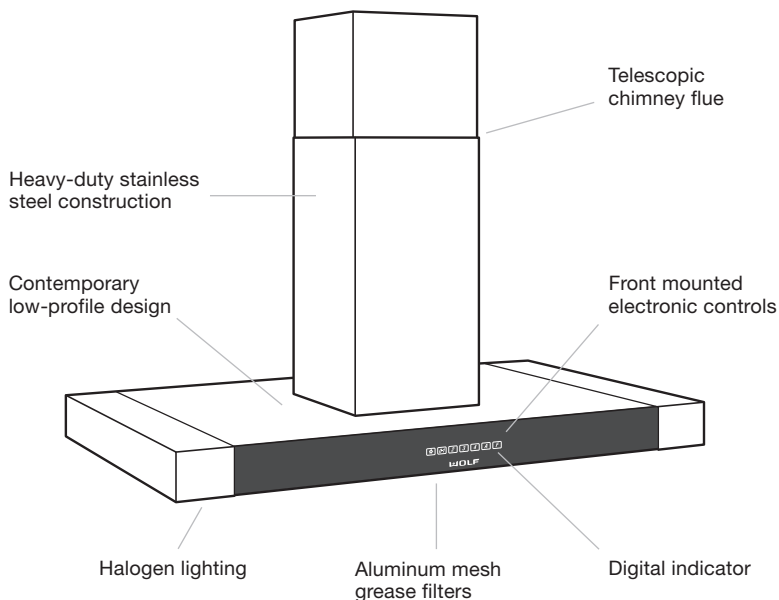

Hood Controls

The Wolf cooktop low-profile hood is operated using the touch control pads on the front face of the hood. Refer to the illustration below.

- L) LIGHTS. Touch the pad once to turn the lights ON, touch a second time to turn the lights ON to a brighter level and touch a third time to turn the lights OFF.
- 1) A touch activates the blower motor at the first speed (icon is illuminated). Press the pad for about two seconds to turn the blower OFF.
- 2) Activates the blower at the second speed.
- 3) Activates the blower at the third speed.
- 4) Activates the blower at the fourth speed.
- A) Touch the pad to set a TIMER which keeps the blower operating at the current speed for 10 minutes.
- F) FILTER. After 30 hours of operation, the icon is illuminated to indicate that the grease filter(s) must be cleaned. After 120 hours, the icon flashes to indicate that the grease filter(s) must be cleaned and the charcoal filter replaced. To reset the hour counter, touch (F) while the icon is illuminated or flashing.

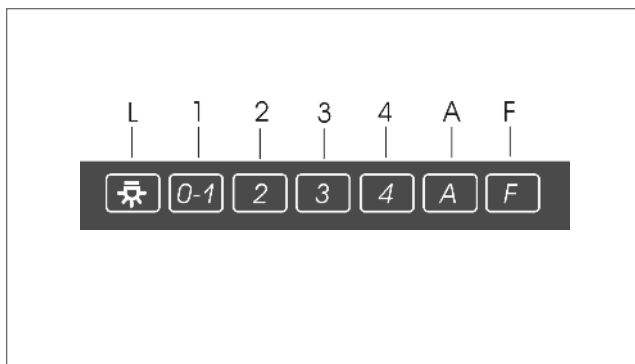

Hood controls.

Heat Sentry Feature

The heat sentry feature turns the ventilation hood on when heat is sensed and adjusts the blower speed automatically. The heat sentry feature is activated when the exhaust from the hood reaches a threshold temperature and deactivated when the exhaust temperature decreases.

If the blower is off, it automatically turns the blower on to HIGH speed. If the blower is on at a lower speed setting, it will automatically adjust to HIGH speed. When the temperature level drops, it adjusts the blower back to the setting on the blower control.

IMPORTANT NOTE: The heat sentry thermostat can start the blower even if the hood is turned off. When this occurs, the blower cannot be turned off by the hood controls. If you must turn off the blower, do it from the main electrical panel.

Halogen Lighting

Wolf cooktop low-profile hoods have halogen lighting with three settings. Halogen bulbs are included with the hood.

LIGHT BULB REPLACEMENT

For replacement, cooktop low-profile hoods require type T4, 12V, 20W halogen bulbs available at hardware stores or through your authorized Wolf dealer. For local dealer information, visit the find a showroom section of our website, wolfappliance.com.

IMPORTANT NOTE: Use a paper towel when handling the replacement halogen bulb to keep oil on fingers from touching the bulb. Failure to do this will shorten the life of the bulb.

- 1) Turn off the blower and lights and allow the halogen bulb to cool before replacing.
- 2) Open the light cover by pressing in on the slots as shown in the illustration below. Remove the old halogen bulb by pulling it straight out of the socket.
- 3) Using a paper towel to handle the new halogen bulb, insert the bulb into the socket. Place the light cover back onto the light assembly.

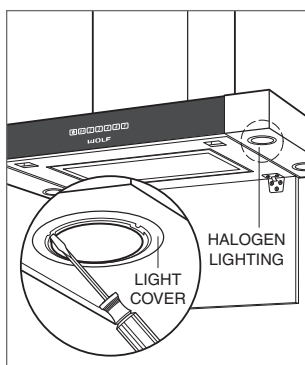

Light bulb replacement.

⚠ CAUTION

Use caution when handling light bulbs. Halogen bulbs get hot instantly and adjacent parts may retain heat.

Grease Filters

The aluminum mesh grease filters should be cleaned approximately every month, depending on use. The (F) touch pad of the hood controls will illuminate to indicate when the filter(s) should be cleaned. This indicator light comes on after approximately 30 hours of operation. To reset the hour counter, touch the (F) touch pad while the icon is illuminated. You may need to clean the filter(s) more often if your cooking style generates large amounts of grease, like frying foods or wok cooking.

The grease filters and filter covers are dishwasher safe and are designed to fit most dishwashers.

GREASE FILTER REMOVAL

To access the grease filter(s), gently pull down on the front edge of the bottom panel and allow it to rotate downward as shown in the illustration below. Push the handle for the filter outward and pull the filter downward to remove.

The aluminum mesh filters and stainless steel covers are dishwasher safe and are designed to fit most dishwashers. Place the filter(s) and filter cover(s) into the dishwasher at approximately 140°F (60°C), or hand wash, and use a biodegradable detergent. When dry, reinstall using the reverse procedure.

IMPORTANT NOTE: Do not operate the ventilation hood without the grease filter(s). This may cause damage to the blower or other internal components of the hood.

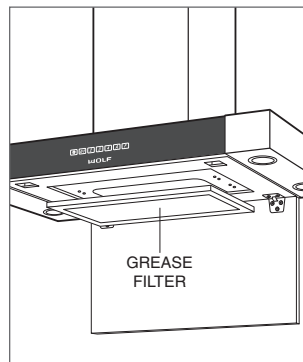

Grease filter removal.

Charcoal Filter

RECIRCULATING APPLICATION

If the ventilation hood is used in a recirculating or non-ducted application, the charcoal filter must be replaced at regular intervals. The (F) touch pad of the hood controls will flash to indicate when the charcoal filter needs to be replaced. This indicator light flashes after approximately 120 hours of operation. To reset the hour counter, press the (F) touch pad while the icon is flashing.

IMPORTANT NOTE: Resetting the 120 hour counter for the charcoal filter will not affect the 30 hour counter for the grease filter.

Replacement charcoal filters are available through your authorized Wolf dealer. For local dealer information, visit the find a showroom section of our website, wolfappliance.com.

CHARCOAL FILTER REMOVAL

First remove the grease filter(s) as described on the previous page. Then remove the charcoal filter as shown in illustration below. Push the catch towards the inside and turn the charcoal filter so that the two filter clips slip out of their seats. Install the new charcoal filter using the reverse procedure.

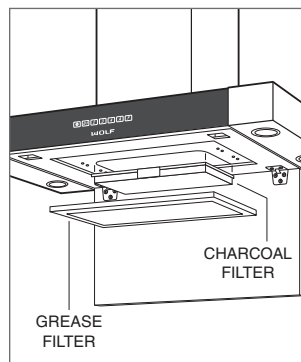

Charcoal filter removal.

Care Recommendations

STAINLESS STEEL EXTERIOR

IMPORTANT NOTE: Do not use abrasive cleaners; they will permanently scratch stainless steel surfaces. Salt and some cooking liquids may pit and stain the surface. Remove these spatters immediately.

Use a spray degreaser to remove fingerprints and greasy spatters. Spray on a cloth and wipe the surface. Buff dry immediately to avoid streaking. For hard water stains, use white vinegar and water.

For general cleaning, use a soft, nonabrasive stainless steel cleaner like Signature polish and apply with a soft lint-free cloth. To bring out the natural luster, lightly wipe the surface with a water-dampened microfiber cloth followed by a dry polishing chamois. All work should follow the grain direction of the finish. Better results are obtained by keeping the cloth in continuous contact with the stainless steel.

Signature polish is available from Signature Limited Laboratory, P. O. Box 13436, Dayton, Ohio 45413, or call 877-376-5474.

CONTROLS

Use a spray degreaser to remove fingerprints and greasy spatters. Spray on a cloth and wipe the surface. Use a clean cloth or sponge and wipe the surface with warm water and a mild detergent. Rinse and dry immediately.

GREASE FILTERS

The aluminum mesh filters and stainless steel filter covers should be cleaned approximately every month, depending on use. You may need to clean the filters more often if your cooking style generates large amounts of grease, like frying foods or wok cooking.

The filters and filter covers are dishwasher safe and are designed to fit most dishwashers. Wolf recommends wiping filters and filter covers to remove any excess grease before placing in the dishwasher. Refer to filter removal on page 10.

Troubleshooting

If your Wolf ventilation hood is not operating properly, use the following troubleshooting guide before calling your Wolf authorized service center. This guide will save you time and trouble and may help you avoid the expense of a service call.

Ventilation hood does not operate.

- Check the household fuse or circuit breaker to see if it has been blown or tripped. A power outage may also have caused a disruption in service.
- No electricity is being supplied to the ventilation hood. Have an electrician verify that the hood is connected to a proper electrical circuit.

Blower runs but lights do not operate.

- Check the light bulbs to see if they have burned out.

DISCONNECTING SWITCH

IMPORTANT NOTE: To reduce the risk of injury, disconnect the power supply before servicing. This hood is equipped with an integral disconnecting switch located inside the blower housing. Refer to the illustration below.

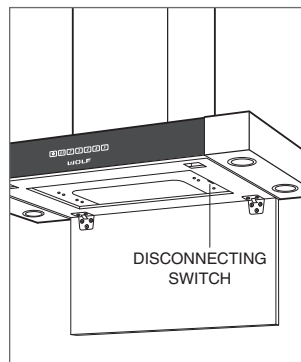

Location of disconnecting switch.

Service Information

When requesting information, literature, replacement parts or service, always refer to the model and serial number of your ventilation hood. This information is found on the product rating plate located on the underside of the hood, above the grease filter. The filter must be removed to access the rating plate. Refer to the illustration on page 3. Record the rating plate information below for future reference.

Model Number: _____

Serial Number: _____

Installation Date: _____

Wolf Authorized Service Center:

Phone: _____

Authorized Wolf Dealer:

Phone: _____

BEFORE CALLING FOR SERVICE

Before calling a Wolf authorized service center, refer to the troubleshooting guide on page 13.

PRODUCT REGISTRATION

Register your new Wolf product today so that we may ensure your satisfaction. You may register by one of the following options:

- 1) Mail in the completed Wolf product registration card.
- 2) Register online at wolfappliance.com.
- 3) Register by phone by calling Wolf customer service at **800-222-7820**.

The model and serial numbers of your unit are printed on the enclosed Wolf product registration card. If you provide us with your e-mail address, we will send you exciting new product updates and recipes as they become available, along with information on special events.

The information and images in this guide are the copyright property of Wolf Appliance, Inc. Neither this guide nor any information or images contained herein may be copied or used in whole or in part without the express written permission of Wolf Appliance, Inc. ©Wolf Appliance, Inc. all rights reserved.

Wolf, Wolf & Design, Wolf Gourmet, W & Design and the color red as applied to knobs are registered trademarks and service marks of Wolf Appliance, Inc. Sub-Zero, Sub-Zero & Design, Dual Refrigeration, Constant Care and The Living Kitchen are registered trademarks and service marks of Sub-Zero, Inc. (collectively, the "Company Marks.") All other trademarks or registered trademarks are property of their respective owners in the United States and other countries.

Wolf Appliance Products Limited Warranty

RESIDENTIAL USE ONLY

FULL TWO YEAR WARRANTY*

For two years from the date of original installation, your Wolf Appliance product warranty covers all parts and labor to repair or replace any part of the product that proves to be defective in materials or workmanship. All service provided by Wolf Appliance under the above warranty must be performed by a Wolf authorized service center, unless otherwise specified by Wolf Appliance. Service will be provided in the home during normal business hours.

LIMITED THIRD THROUGH FIFTH YEAR WARRANTY

From the third through fifth year from the date of original installation, Wolf Appliance will repair or replace the following parts that prove to be defective in materials or workmanship: gas burners (excluding appearance), electric heating elements, blower motors (ventilation hoods), electronic control boards, magnetron tubes and induction generators. Labor to remove and replace defective parts is not covered. Wolf Appliance recommends that you use a Wolf authorized service center to perform such service.

LIMITED LIFETIME WARRANTY

For the life of the product, Wolf Appliance will repair or replace any outdoor gas grill body or hood that rusts through due to defective material or workmanship. Labor to remove and replace defective parts is not covered. Wolf Appliance recommends that you use a Wolf authorized service center to perform such service.

TERMS APPLICABLE TO EACH WARRANTY

The warranty applies only to products installed for normal residential use. The warranty applies only to products installed in any one of the fifty states of the United States, the District of Columbia or the ten provinces of Canada. This warranty does not cover any parts or labor to correct any defect caused by negligence, accident or improper use, maintenance, installation, service or repair.

THE REMEDIES DESCRIBED ABOVE FOR EACH WARRANTY ARE THE ONLY ONES THAT WOLF APPLIANCE, INC. WILL PROVIDE, EITHER UNDER THIS WARRANTY OR UNDER ANY WARRANTY ARISING BY OPERATION OF LAW. WOLF APPLIANCE, INC. WILL NOT BE RESPONSIBLE FOR ANY CONSEQUENTIAL OR INCIDENTAL DAMAGES ARISING FROM THE BREACH OF THIS WARRANTY OR ANY OTHER WARRANTY, WHETHER EXPRESS, IMPLIED OR STATUTORY.

Some states do not allow the exclusion or limitation of incidental or consequential damages, so the above limitation or exclusion may not apply to you. This warranty gives you specific legal rights and you may also have other legal rights that vary from state to state.

To receive parts and/or service and the name of the Wolf authorized service center nearest you, contact Wolf Appliance, Inc., P.O. Box 44848, Madison, WI 53744; check the contact & support section of our website, wolfappliance.com or call 800-332-9513.

*Stainless steel doors, panels, handles, product frames and interior surfaces are covered by a limited 60-day parts and labor warranty for cosmetic defects.





WOLF APPLIANCE, INC. P. O. BOX 44848 MADISON, WI 53744 WOLFAPPLIANCE.COM 800.332.9513

817000 REV-A

5/2010

