

SUB-ZERO DESIGN GUIDE



SUB-ZERO



Contents

Built-In Refrigeration	3
PRO 48 Refrigeration	44
Integrated Refrigeration	50
Wine Storage	64
Undercounter Refrigeration	84
Sub-Zero Warranties	92

Features and specifications are subject to change at any time without notice. Visit subzero.com/specs for the most up-to-date information.

IMPORTANT NOTE: Throughout this guide, dimensions in parentheses are millimeters unless otherwise specified.

Built-In Refrigeration. For the built-in line, Sub-Zero designers and engineers took a fresh look at everything, inside and out. Exterior refinements include redesigned grilles and lower-profile hinges. Inside, new technology in food preservation makes the built-in line nothing short of revolutionary.

BUILT-IN MODELS

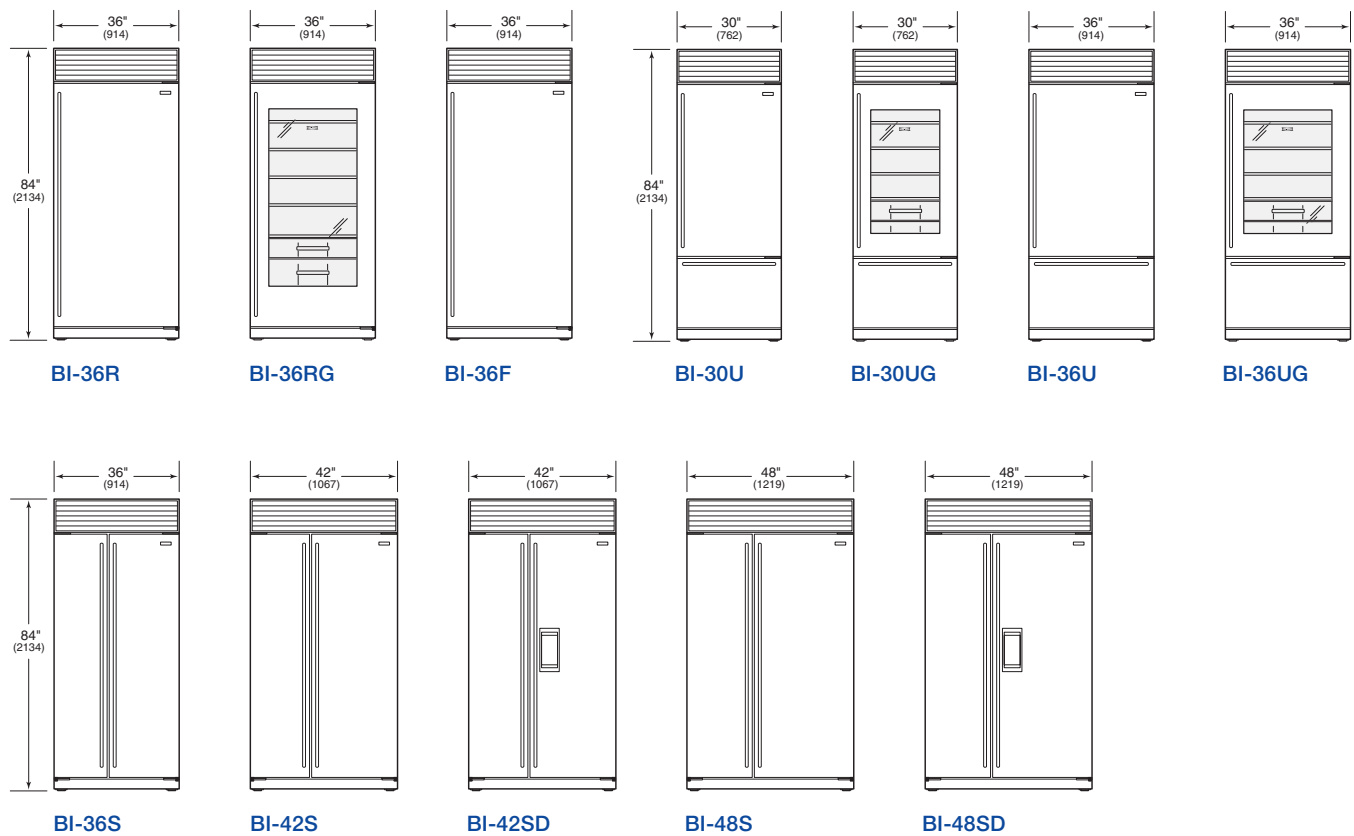

KEY FEATURES

- Four distinct design approaches: framed, overlay, flush inset and stainless steel.
- Handle options coordinate with handles of Wolf cooking products.
- Dual refrigeration; two compressors preserve food's goodness in two sealed compartments.
- Energy efficient; many models are ENERGY STAR® qualified.
- Advanced water filtration and air purification systems.
- Crisper and deli drawers form a lower-temperature zone for produce and meats.
- Flip-up grille provides easy access for quick routine maintenance.
- All models are Star-K certified.

Built-In Design Options. A design classic is now even better. Four distinct design approaches provide limitless flexibility for creating a beautiful kitchen. Lower-profile hinges enable the built-in units to blend more seamlessly with surrounding cabinetry.



Framed. Custom cabinetry panels slide into the door to blend into the kitchen design. Shown with full-length handle and louvered grille option for the traditional Sub-Zero look.



Overlay. Custom cabinet overlay panels can be combined with unique hardware for design flexibility. Shown with pro handle option to complement Wolf ranges.



Flush Inset. This design option allows for a flush door and grille. Stainless steel panels are available as sales accessories. Shown with tubular handle option to mirror Wolf built-in ovens.



Stainless Steel. For a professional look, this design requires no customization. To complement the look of Wolf ranges, choose the pro handle option shown here.

Built-In Models

SPECIFICATIONS

Interior Capacity	R cu ft (L)	F cu ft (L)
ALL REFRIGERATOR / ALL FREEZER MODELS		
BI-36R	23.4 (663)	
BI-36RG	23.2 (657)	
BI-36F		22.8 (646)
OVER-AND-UNDER MODELS		
BI-30U	13.0 (368)	4.1 (116)
BI-30UG	13.0 (368)	4.1 (116)
BI-36U	16.2 (459)	5.3 (150)
BI-36UG	16.1 (456)	5.3 (150)
SIDE-BY-SIDE MODELS		
BI-36S	12.2 (346)	8.0 (227)
BI-42S	16.1 (456)	8.0 (227)
BI-42SD	16.0 (453)	8.1 (230)
BI-48S	18.8 (532)	9.5 (269)
BI-48SD	18.7 (530)	9.7 (265)

Shipping Weight	lbs (kg)
ALL REFRIGERATOR / ALL FREEZER MODELS	
BI-36R	420 (191)
BI-36RG	430 (195)
BI-36F	406 (184)
OVER-AND-UNDER MODELS	
BI-30U	462 (210)
BI-30UG	476 (216)
BI-36U	515 (234)
BI-36UG	529 (240)
SIDE-BY-SIDE MODELS	
BI-36S	538 (244)
BI-42S	582 (264)
BI-42SD	608 (276)
BI-48S	630 (286)
BI-48SD	656 (298)

All Refrigerator / All Freezer Models

OVERALL DIMENSIONS

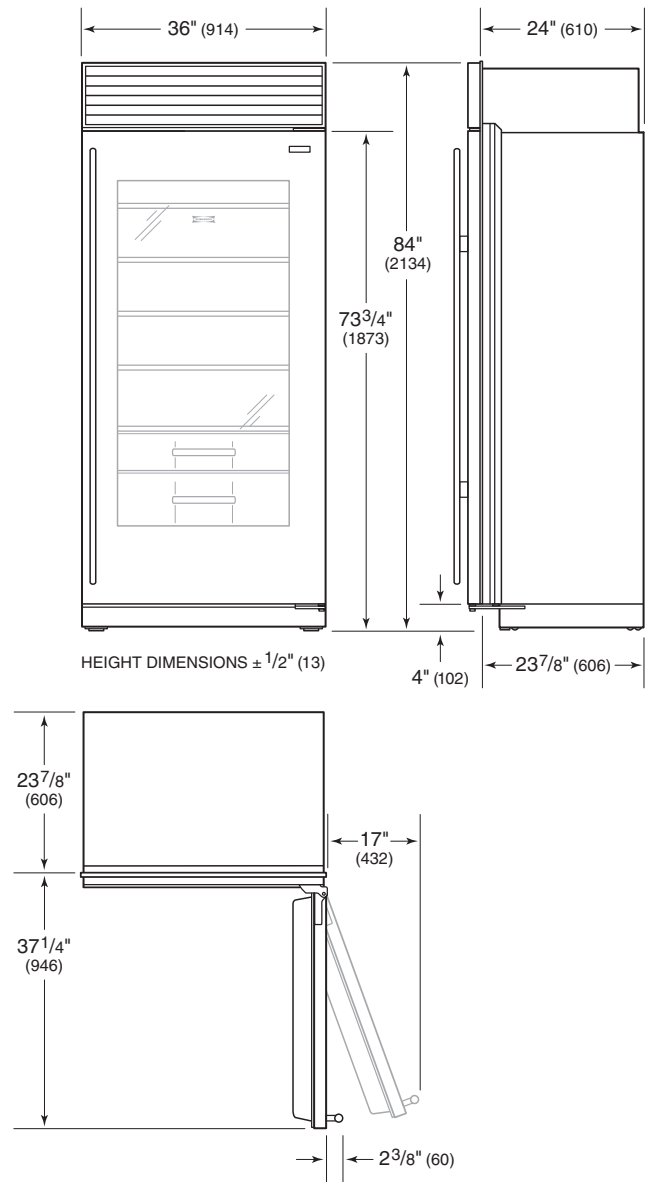

MODELS BI-36R, BI-36RG AND BI-36F

Shipping weights and overall dimensions are based on stainless steel models. For flush inset applications, add 1/2" (13) to door clearance dimensions.

Over-and-Under Models

OVERALL DIMENSIONS

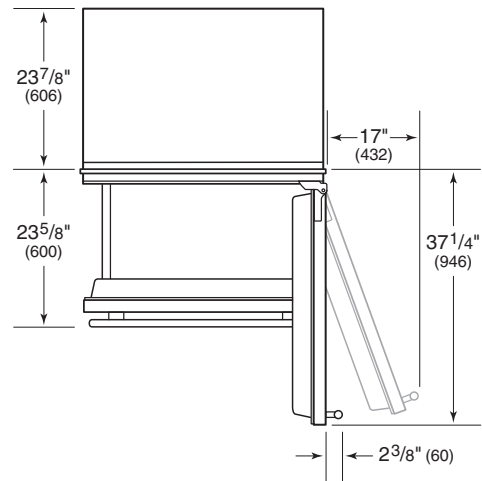
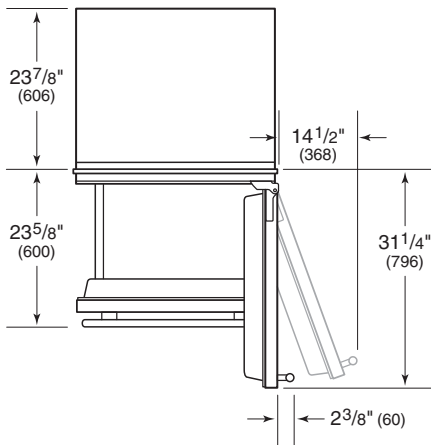
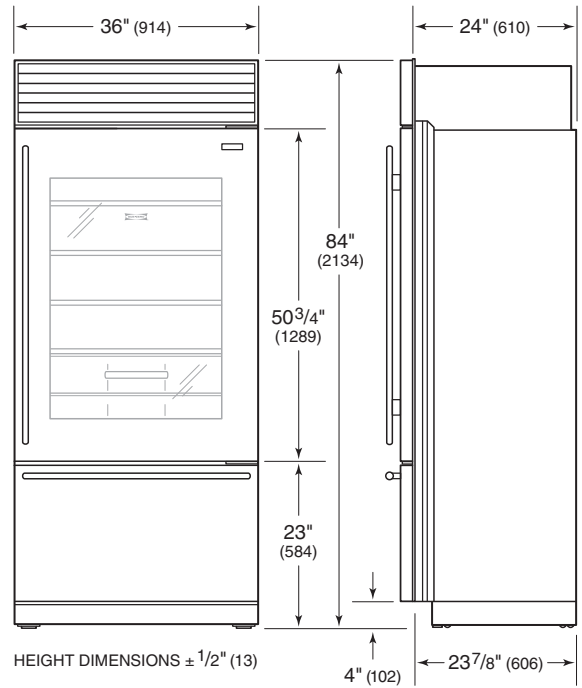
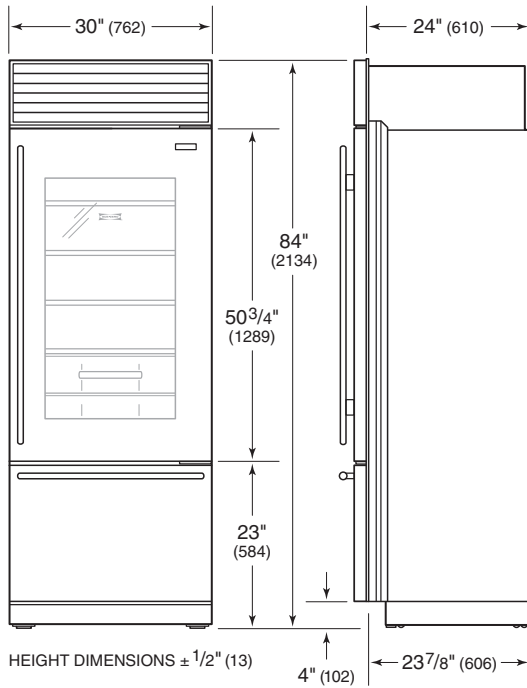

MODELS BI-30U AND BI-30UG

MODELS BI-36U AND BI-36UG

Side-by-Side Models

OVERALL DIMENSIONS

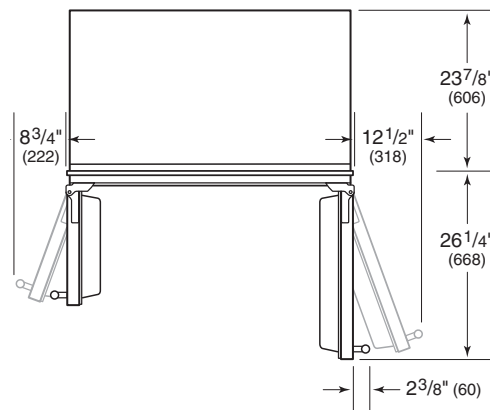
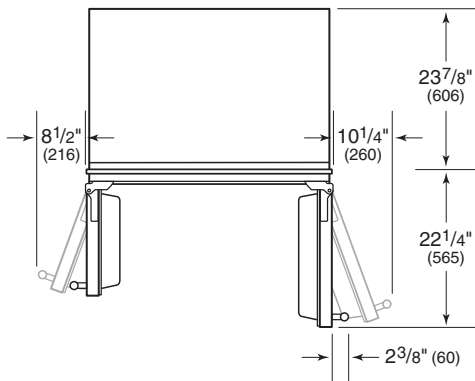
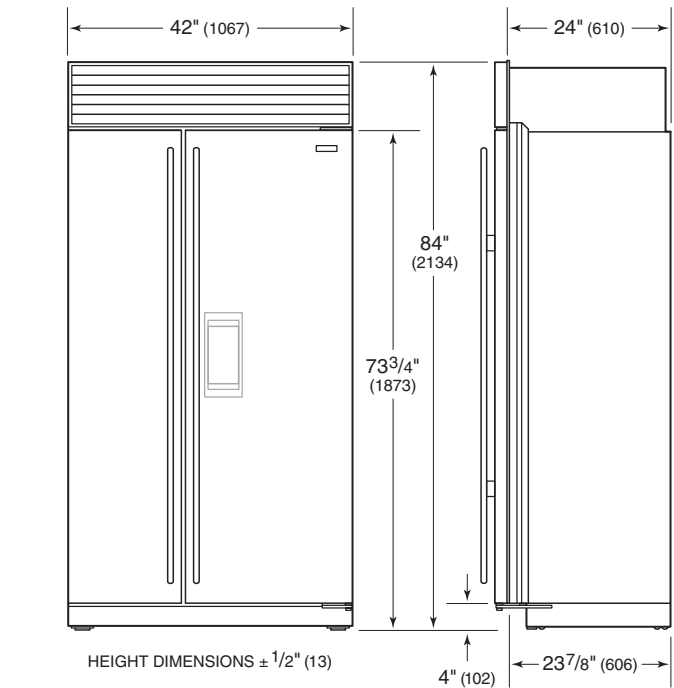
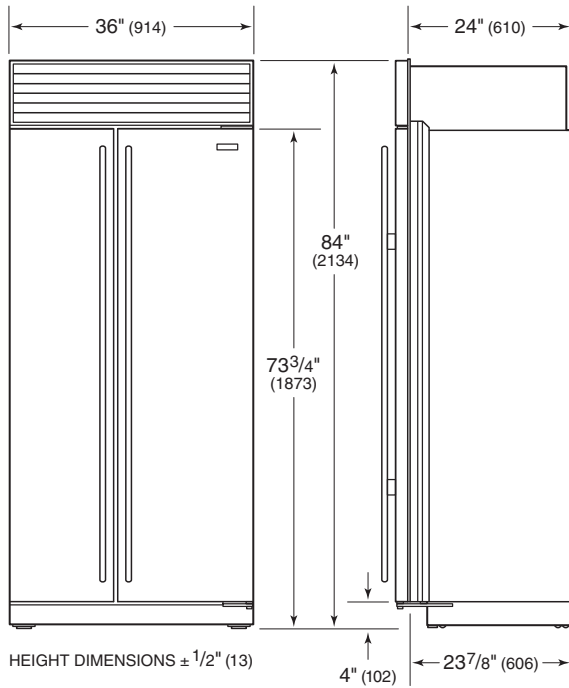

MODEL BI-36S

MODELS BI-42S AND BI-42SD

Overall dimensions are based on stainless steel models.
 For flush inset applications, add 1/2" (13) to door clearance dimensions.

Side-by-Side Models

OVERALL DIMENSIONS

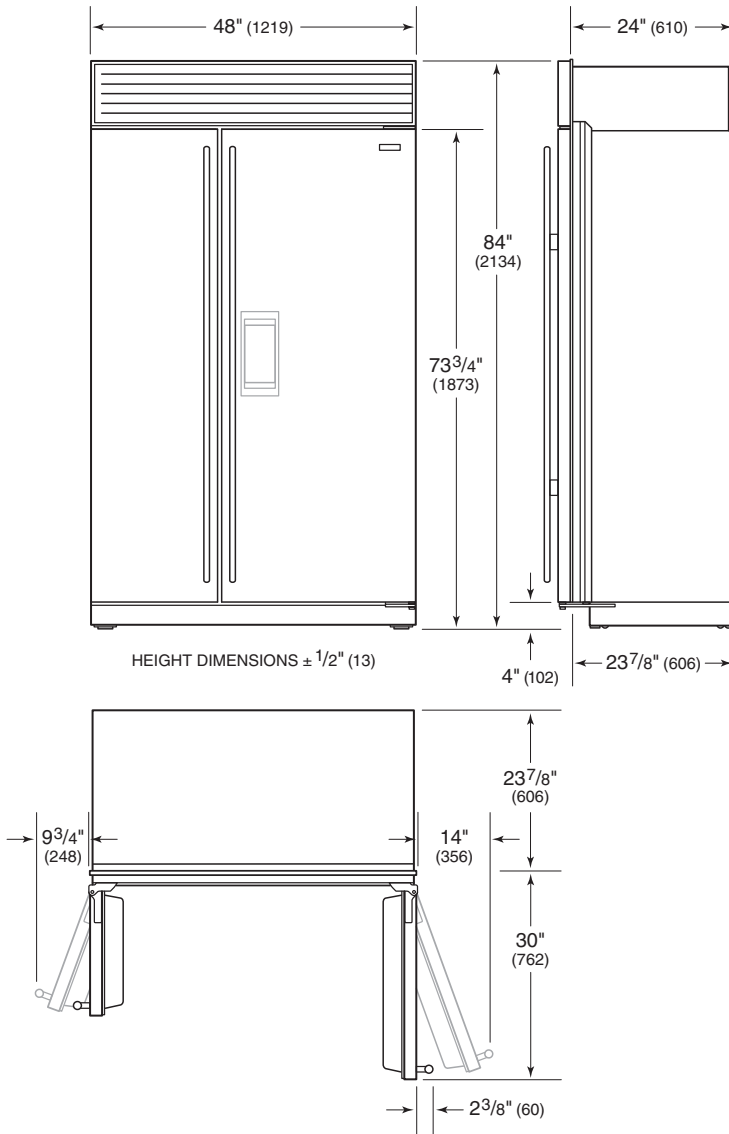

MODELS BI-48S AND BI-48SD

Built-In Models

STANDARD INSTALLATION

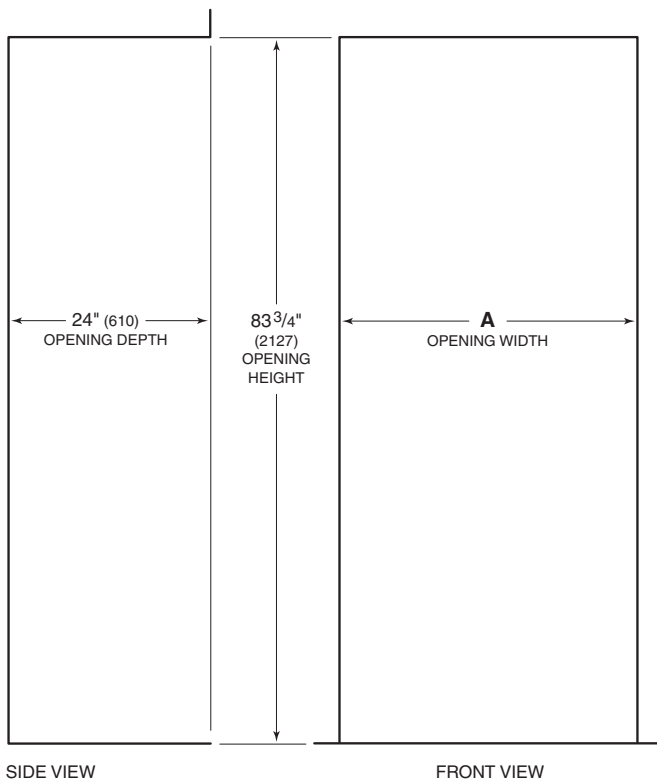
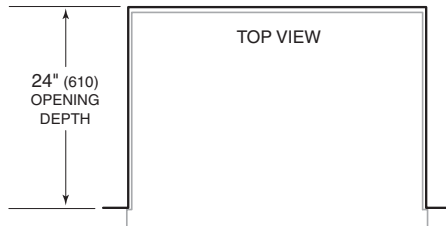

Opening Width	A
BI-36R, BI-36RG and BI-36F	35 ¹ / ₂ " (902)
BI-30U and BI-30UG	29 ¹ / ₂ " (746)
BI-36U and BI-36UG	35 ¹ / ₂ " (902)
BI-36S	35 ¹ / ₂ " (902)
BI-42S and BI-42SD	41 ¹ / ₂ " (1054)
BI-48S and BI-48SD	47 ¹ / ₂ " (1206)

IMPORTANT NOTE: If two units are installed side by side, refer to pages 30–31 for dual standard installations.

Stainless steel models are ready to install out of the box.

Planning Information

ELECTRICAL REQUIREMENTS

For all built-in models, the electrical supply should be located within the shaded area shown in the illustration. Follow the National Electrical Code and local codes and ordinances when installing the receptacle. A separate circuit servicing only this appliance is required. A ground fault circuit interrupter (GFCI) is not recommended and may cause interruption of operation.

Electrical Requirements	
Power Supply	115 V AC, 60 Hz
Circuit Breaker	15 amp
Receptacle	3-prong grounding-type

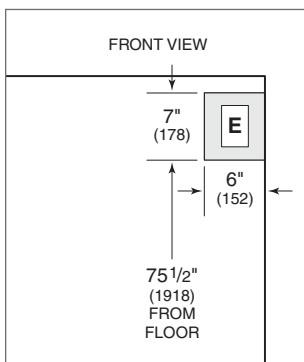

Location of electrical supply.

PLUMBING REQUIREMENTS

All built-in models with an automatic ice maker come with a microbiological water filtration system. The water supply line should be located within the shaded area shown in the illustrations. The water supply line should be connected to the house supply with an easily accessible shut-off valve between the supply and the unit. Do not use self-piercing valves. A saddle valve kit (4200880) is available through your authorized Sub-Zero dealer. The water line must not interfere with installation of the anti-tip brackets.

IMPORTANT NOTE: A reverse osmosis system can be used provided there is constant water pressure of 30 psi (2.1 bar) to 100 psi (6.9 bar) supplied to the unit at all times. In this application, the microbiological water filtration system should be set to bypass mode by removing the water filter cartridge and inserting the bypass plug (7005018) available through your authorized Sub-Zero dealer. Installation instructions packed with the unit will outline this procedure.

Plumbing Requirements	
Water Supply Line	1/4" OD copper line
Water Pressure	30–100 psi (2.1–6.9 bar)
Excess Water Line for Connection	36" (914)

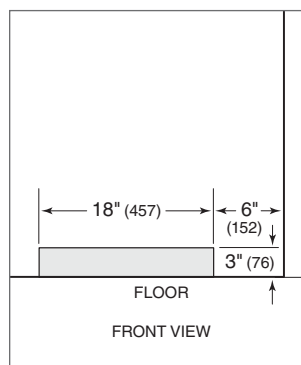

Location of water supply—rear.

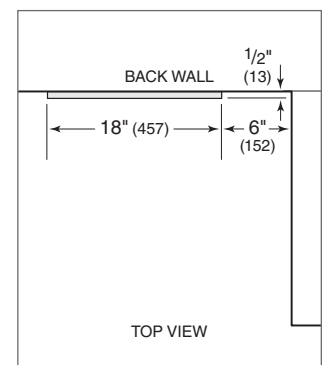

Location of water supply—bottom.



Custom cabinetry panels slide into the door to blend into the kitchen design. Shown with full-length handle and louvered grille option for the traditional Sub-Zero look.

Framed Application

IMPORTANT NOTE: The framed application is not a separate model. This is an overlay unit in a framed application.

The framed panel design option is available for all built-in overlay models. You must specify panels, full-length handles and a framed grille insert to achieve the traditional framed look. For exact door panel dimensions refer to framed panel specifications on the following pages. Also refer to the full-scale templates at the end of this section for additional panel and handle considerations.

Optional extended full-length handles that provide additional finger clearance for raised panels are available through your authorized Sub-Zero dealer.

Framed Panel Requirements

MAX WEIGHT PER PANEL

BI-36R, BI-36RG and BI-36F	75 lbs (34 kg)
All Other Framed Panels	50 lbs (23 kg)

MIN PANEL THICKNESS

All Framed Panels	1/4" (6)
-------------------	----------

Framed Panels

If the thickness of the custom panels is less than $\frac{1}{4}$ " (6), they must be backed up with a sheet of shim material to build the total thickness to $\frac{1}{4}$ " (6). If the panel is thicker than $\frac{1}{4}$ " (6), a routed edge must be provided around the panel to ensure a proper fit. Refer to the illustrations.

IMPORTANT NOTE: For framed design applications, routing, recessing or optional extended handles may be required on raised panels for finger clearance under the handle. Refer to the full-scale templates at the end of this section.

IMPORTANT NOTE: Do not cover a glass door with a solid panel. Also, the edges of the window cut-out will need to be finished, as they will be exposed.

IMPORTANT NOTE: When installing two units in a side-by-side application, refer to pages 30–31 for dual standard installations. Be aware that rough opening dimensions are different for this application.

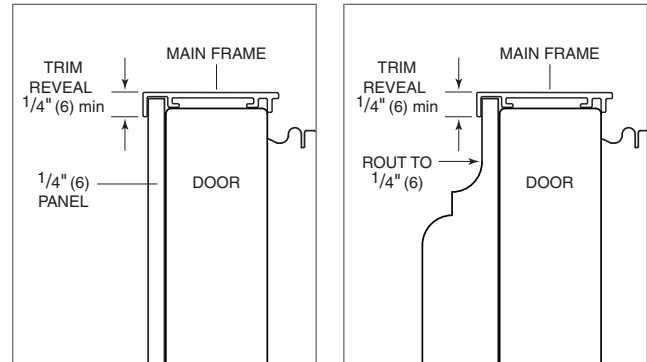

Panels $\frac{1}{4}$ " (6) thick or less.

Panels thicker than $\frac{1}{4}$ " (6).

Framed Panels

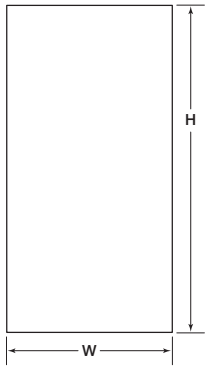

BI-36R / BI-36F

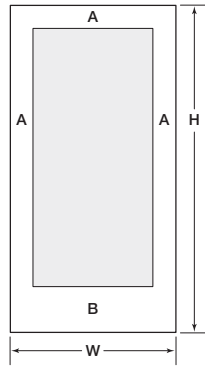

BI-36RG

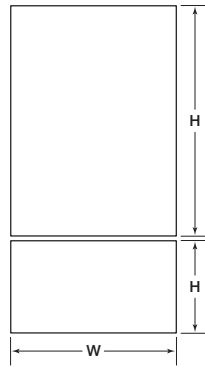

BI-30U / BI-36U

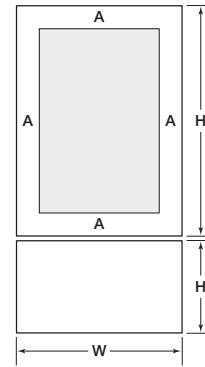

BI-30UG / BI-36UG

Models BI-36R, BI-36RG and BI-36F			
REFRIGERATOR/FREEZER	W	H	
Door Panel	35 ³ / ₄ " (908)	69 ⁹ / ₁₆ " (1767)	
BI-36RG	W	H	
Window Cut-Out	25 ¹ / ₂ " (648)	54 ¹ / ₁₆ " (1373)	
	A	B	
Cut-Out Location	5 ³ / ₁₆ " (132)	10 ⁵ / ₁₆ " (262)	

Models BI-30U and BI-30UG			
REFRIGERATOR	W	H	
Door Panel	29 ³ / ₄ " (756)	49 ¹⁵ / ₁₆ " (1268)	
FREEZER	W	H	
Drawer Panel	29 ³ / ₄ " (756)	18 ¹¹ / ₁₆ " (475)	
BI-30UG	W	H	
Window Cut-Out	19 ¹ / ₂ " (495)	39 ¹¹ / ₁₆ " (1008)	
		A	
Cut-Out Location		5 ³ / ₁₆ " (132)	

Models BI-36U and BI-36UG			
REFRIGERATOR	W	H	
Door Panel	35 ³ / ₄ " (908)	49 ¹⁵ / ₁₆ " (1268)	
FREEZER	W	H	
Drawer Panel	35 ³ / ₄ " (908)	18 ¹¹ / ₁₆ " (475)	
BI-36UG	W	H	
Window Cut-Out	25 ¹ / ₂ " (648)	39 ¹¹ / ₁₆ " (1008)	
		A	
Cut-Out Location		5 ³ / ₁₆ " (132)	

Framed Panels

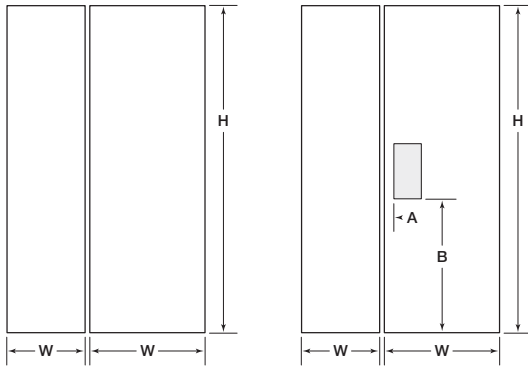

BI-36S / BI-42S / BI-48S BI-42SD / BI-48SD

Model BI-36S			
REFRIGERATOR		W	H
Door Panel	19 ¹³ / ₁₆ " (503)	69 ⁹ / ₁₆ " (1767)	
FREEZER		W	H
Door Panel	15 ⁷ / ₁₆ " (392)	69 ⁹ / ₁₆ " (1767)	

Models BI-42S and BI-42SD			
REFRIGERATOR		W	H
Door Panel	24 ¹³ / ₁₆ " (630)	69 ⁹ / ₁₆ " (1767)	
FREEZER		W	H
Door Panel	16 ⁷ / ₁₆ " (418)	69 ⁹ / ₁₆ " (1767)	
BI-42SD		W	H
Dispenser Cut-Out	5 ⁷ / ₈ " (149)	12 ⁷ / ₁₆ " (316)	
Cut-Out Location		A	B
	1 ⁷ / ₈ " (48)	28 ³ / ₄ " (730)	

Models BI-48S and BI-48SD			
REFRIGERATOR		W	H
Door Panel	28 ¹ / ₂ " (724)	69 ⁹ / ₁₆ " (1767)	
FREEZER		W	H
Door Panel	18 ³ / ₄ " (476)	69 ⁹ / ₁₆ " (1767)	
BI-48SD		W	H
Dispenser Cut-Out	5 ⁷ / ₈ " (149)	12 ⁷ / ₁₆ " (316)	
Cut-Out Location		A	B
	1 ⁷ / ₈ " (48)	28 ³ / ₄ " (730)	

For models BI-42SD and BI-48SD, panel thickness in the dispenser area can range from 1/4" (6) to a maximum of 1 1/8" (29). If the panel is thicker, you must rout out a minimum 1/4" (6) flat landing area to accommodate the glasswell bezel.

Framed Application

OPTIONAL GRILLE PANEL

A panel grille, providing an 84" (2134) finished height, is standard on overlay models. Optional panel grilles are available for 83" (2108) and 88" (2235) finished heights.

Grille panel dimensions listed are for a standard 84" (2134) finished height. For an 83" (2108) finished height, subtract 1" (25) from grille panel height dimensions. For an 88" (2235) finished height, add 4" (102) to height dimensions.

Optional Grille Panel	W	H
30" (762) Models	29 ³ / ₄ " (756)	8 ¹⁵ / ₁₆ " (227)
36" (914) Models	35 ³ / ₄ " (908)	8 ¹⁵ / ₁₆ " (227)
42" (1067) Models	41 ³ / ₄ " (1060)	8 ¹⁵ / ₁₆ " (227)
48" (1219) Models	47 ³ / ₄ " (1213)	8 ¹⁵ / ₁₆ " (227)

Grille Panel Requirements	
MAX WEIGHT	
Grille Panel	13 lbs (6 kg)
MIN PANEL THICKNESS	
Grille Panel	1/4" (6)



Optional grille panel.

Framed Application

PARTIAL FRAMED OPTION

If you choose not to use custom panels above and below the glasswell for dispenser model BI-42SD or BI-48SD, a stainless steel insert panel is available as a sales accessory. This accessory kit includes partial framed molding and stainless steel panel to provide a spill-resistant finish above and below the glasswell on the refrigerator door only. The partial framed accessory kit (7004855) is available through your authorized Sub-Zero dealer. Refer to panel dimensions for the partial framed option below.

IMPORTANT NOTE: When using raised panels with the partial framed kit, a 1/2" (13) trim reveal down to 1/4" (6) thickness is necessary at the bezel for the panels to fit properly.



Partial framed kit.

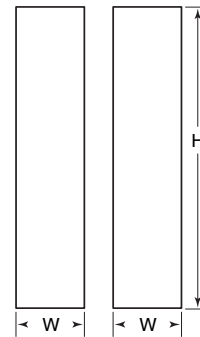

BI-42SD / BI-48SD
Partial framed option.

Optional Partial Framed Panels			
BI-42SD		W	H
Refrigerator Panel	15 ¹ / ₁₆ " (383)	69 ⁹ / ₁₆ " (1767)	
Freezer Panel	16 ⁷ / ₁₆ " (418)	69 ⁹ / ₁₆ " (1767)	
BI-48SD		W	H
Refrigerator Panel	16 ³ / ₄ " (425)	69 ⁹ / ₁₆ " (1767)	
Freezer Panel	18 ³ / ₄ " (476)	69 ⁹ / ₁₆ " (1767)	



Custom cabinet overlay panels can be combined with unique hardware for design flexibility. Shown with pro handle option to complement Wolf ranges and rangetops.

Overlay Panels

If you and your client have ordered an overlay model, you will be adding panels and handles to give the unit a more custom look. The overlay panel design option is available for all built-in overlay models. For exact door panel dimensions, refer to overlay panel specifications on the following pages.

IMPORTANT NOTE: Overlay models can be used in an overlay or a flush inset application. Be aware that the application specified will affect panel sizes, rough opening dimensions and installation.

The overlay design allows decorative panels to cover the door trim for a more seamless appearance that blends with the design of the room. The most common way to achieve this look is to work with three panels—the decorative overlay panel, which is typically $\frac{3}{4}$ " (19), a .10" (3) spacer panel and a $\frac{1}{4}$ " (6) backer panel. Depending on your cabinet manufacturer, this could also be one panel routed for different dimensions.

Regardless of the physical construction of the panels (three-panel assembly or routed panel), you will need to follow the overlay panel specifications on the following pages for exact sizing and panel placement to ensure a proper fit.

Overlay Panel Requirements	
MAX WEIGHT PER PANEL	
BI-36R, BI-36RG and BI-36F	75 lbs (34 kg)
All Other Overlay Models	50 lbs (23 kg)
Grille Panel	13 lbs (6 kg)
MIN PANEL THICKNESS	
All Overlay Panels	$\frac{5}{8}$ " (16)

Overlay Panels

The illustrations provide a cross section view of the three-panel assembly, showing placement of the trim and a rear view of the three-panel assembly with critical dimensions, standard for all built-in models.

Overlay grille panels for the panel grille match the design of the overlay door panels. Dimensions for the grille panel are listed in the overlay panel specifications on the following pages.

IMPORTANT NOTE: On glass door models, the edges of the overlay, spacer and backer panels of the window cut-out will need to be finished, as they will be exposed.

IMPORTANT NOTE: When installing two units in a side-by-side application, refer to pages 30–31 for dual standard installations. Be aware that rough opening dimensions are different for this application.

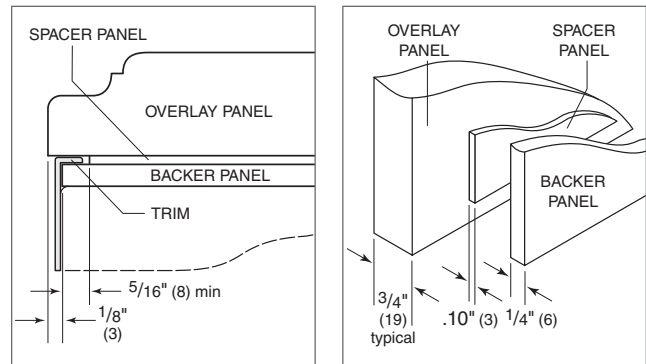

Panel assembly cross section. Panel assembly rear view.

⚠ CAUTION

Do not exceed overlay panel dimensions, as this could cause damage to panels and the Sub-Zero unit.

Overlay Panels

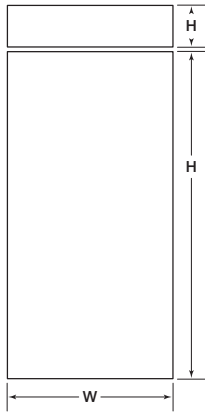

BI-36R / BI-36F

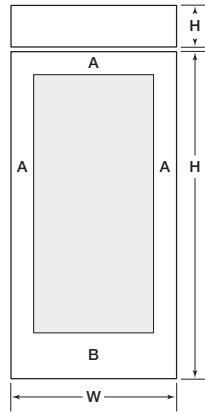

BI-36RG

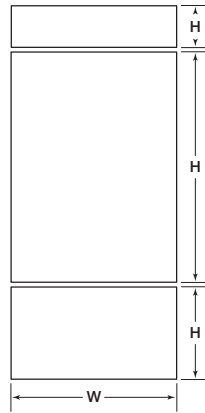

BI-30U / BI-36U

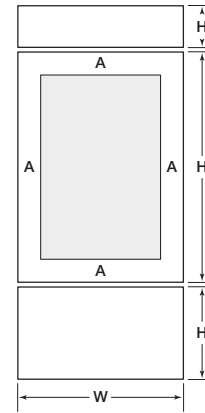

BI-30UG / BI-36UG

Models BI-36R, BI-36RG and BI-36F			
REFRIGERATOR / FREEZER	W	H	
Overlay Panel	36" (914)	69 ³ / ₄ " (1772)	
Spacer Panel	35 ¹ / ₈ " (892)	68 ¹⁵ / ₁₆ " (1751)	
Backer Panel	35 ³ / ₄ " (908)	69 ⁹ / ₁₆ " (1767)	
GRILLE	W	H	
Overlay Panel	36" (914)	9 ¹ / ₄ " (235)*	
Spacer Panel	35 ¹ / ₈ " (892)	8 ⁵ / ₁₆ " (211)	
Backer Panel	35 ³ / ₄ " (908)	8 ¹⁵ / ₁₆ " (227)	
BI-36RG	W	H	
Window Cut-Out	25 ¹ / ₂ " (648)	54 ¹ / ₈ " (1375)	
	A	B	
Cut-Out Location	5 ¹ / ₄ " (133)	10 ³ / ₈ " (264)	

Models BI-30U and BI-30UG			
REFRIGERATOR	W	H	
Overlay Panel	30" (762)	50 ¹ / ₈ " (1273)	
Spacer Panel	29 ¹ / ₈ " (740)	49 ⁵ / ₁₆ " (1253)	
Backer Panel	29 ³ / ₄ " (756)	49 ¹⁵ / ₁₆ " (1268)	
FREEZER	W	H	
Overlay Panel	30" (762)	19" (483)	
Spacer Panel	29 ¹ / ₈ " (740)	18 ¹ / ₁₆ " (459)	
Backer Panel	29 ³ / ₄ " (756)	18 ¹¹ / ₁₆ " (475)	
GRILLE	W	H	
Overlay Panel	30" (762)	9 ¹ / ₄ " (235)*	
Spacer Panel	29 ¹ / ₈ " (740)	8 ⁵ / ₁₆ " (211)	
Backer Panel	29 ³ / ₄ " (756)	8 ¹⁵ / ₁₆ " (227)	
BI-30UG	W	H	
Window Cut-Out	19 ¹ / ₂ " (495)	39 ⁵ / ₈ " (1006)	
		A	
Cut-Out Location		5 ¹ / ₄ " (133)	

Models BI-36U and BI-36UG			
REFRIGERATOR	W	H	
Overlay Panel	36" (914)	50 ¹ / ₈ " (1273)	
Spacer Panel	35 ¹ / ₈ " (892)	49 ⁵ / ₁₆ " (1253)	
Backer Panel	35 ³ / ₄ " (908)	49 ¹⁵ / ₁₆ " (1268)	
FREEZER	W	H	
Overlay Panel	36" (914)	19" (483)	
Spacer Panel	35 ¹ / ₈ " (892)	18 ¹ / ₁₆ " (459)	
Backer Panel	35 ³ / ₄ " (908)	18 ¹¹ / ₁₆ " (475)	
GRILLE	W	H	
Overlay Panel	36" (914)	9 ¹ / ₄ " (235)*	
Spacer Panel	35 ¹ / ₈ " (892)	8 ⁵ / ₁₆ " (211)	
Backer Panel	35 ³ / ₄ " (908)	8 ¹⁵ / ₁₆ " (227)	
BI-36UG	W	H	
Window Cut-Out	25 ¹ / ₂ " (648)	39 ⁵ / ₈ " (1006)	
		A	
Cut-Out Location		5 ¹ / ₄ " (133)	

*Panel height may be increased by 1/2" (13) to hide upper main frame. For more information, refer to the built-in panel configurator at subzero.com/trade/panels.

Grille panel dimensions listed are for a standard 84" (2134) finished height. For an 83" (2108) finished height, subtract 1" (25) from grille panel height dimensions. For an 88" (2235) finished height, add 4" (102) to height dimensions. An 83" (2108) or 88" (2235) panel grille must be ordered to accept an 83" (2108) or 88" (2235) custom panel. Width dimensions do not vary.

Overlay Panels

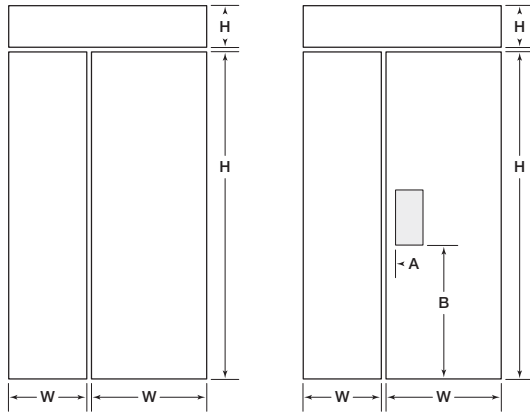

BI-36S / BI-42S / BI-48S BI-42SD / BI-48SD

Model BI-36S			
	W	H	
REFRIGERATOR			
Overlay Panel	20 ¹ / ₁₆ " (51)	69 ³ / ₄ " (1772)	
Spacer Panel	19 ³ / ₁₆ " (487)	68 ¹⁵ / ₁₆ " (1751)	
Backer Panel	19 ¹³ / ₁₆ " (503)	69 ⁹ / ₁₆ " (1767)	
FREEZER			
Overlay Panel	15 ¹¹ / ₁₆ " (398)	69 ³ / ₄ " (1772)	
Spacer Panel	14 ¹³ / ₁₆ " (376)	68 ¹⁵ / ₁₆ " (1751)	
Backer Panel	15 ⁷ / ₁₆ " (392)	69 ⁹ / ₁₆ " (1767)	
GRILLE			
Overlay Panel	36" (914)	9 ¹ / ₄ " (235)*	
Spacer Panel	35 ¹ / ₈ " (892)	8 ⁵ / ₁₆ " (211)	
Backer Panel	35 ³ / ₄ " (908)	8 ¹⁵ / ₁₆ " (227)	

Models BI-42S and BI-42SD			
	W	H	
REFRIGERATOR			
Overlay Panel	25 ¹ / ₁₆ " (637)	69 ³ / ₄ " (1772)	
Spacer Panel	24 ³ / ₁₆ " (614)	68 ¹⁵ / ₁₆ " (1751)	
Backer Panel	24 ¹³ / ₁₆ " (630)	69 ⁹ / ₁₆ " (1767)	
FREEZER			
Overlay Panel	16 ¹¹ / ₁₆ " (424)	69 ³ / ₄ " (1772)	
Spacer Panel	15 ¹³ / ₁₆ " (402)	68 ¹⁵ / ₁₆ " (1751)	
Backer Panel	16 ⁷ / ₁₆ " (418)	69 ⁹ / ₁₆ " (1767)	
GRILLE			
Overlay Panel	42" (1067)	9 ¹ / ₄ " (235)*	
Spacer Panel	41 ¹ / ₈ " (1045)	8 ⁵ / ₁₆ " (211)	
Backer Panel	41 ³ / ₄ " (1060)	8 ¹⁵ / ₁₆ " (227)	
BI-42SD			
Dispenser Cut-Out	5 ⁷ / ₈ " (149)	12 ⁷ / ₁₆ " (316)	
	A	B	
Cut-Out Location	2" (51)	28 ¹³ / ₁₆ " (732)	

Models BI-48S and BI-48SD			
	W	H	
REFRIGERATOR			
Overlay Panel	28 ³ / ₄ " (730)	69 ³ / ₄ " (1772)	
Spacer Panel	27 ⁷ / ₈ " (708)	68 ¹⁵ / ₁₆ " (1751)	
Backer Panel	28 ¹ / ₂ " (724)	69 ⁹ / ₁₆ " (1767)	
FREEZER			
Overlay Panel	19" (483)	69 ³ / ₄ " (1772)	
Spacer Panel	18 ¹ / ₈ " (460)	68 ¹⁵ / ₁₆ " (1751)	
Backer Panel	18 ³ / ₄ " (476)	69 ⁹ / ₁₆ " (1767)	
GRILLE			
Overlay Panel	48" (1219)	9 ¹ / ₄ " (235)*	
Spacer Panel	47 ¹ / ₈ " (1197)	8 ⁵ / ₁₆ " (211)	
Backer Panel	47 ³ / ₄ " (1213)	8 ¹⁵ / ₁₆ " (227)	
BI-48SD			
Dispenser Cut-Out	5 ⁷ / ₈ " (149)	12 ⁷ / ₁₆ " (316)	
	A	B	
Cut-Out Location	2" (51)	28 ¹³ / ₁₆ " (732)	

*Panel height may be increased by 1/2" (13) to hide upper main frame. For more information, refer to the built-in panel configurator at subzero.com/trade/panels.

Grille panel dimensions listed are for a standard 84" (2134) finished height. For an 83" (2108) finished height, subtract 1" (25) from grille panel height dimensions. For an 88" (2235) finished height, add 4" (102) to height dimensions. An 83" (2108) or 88" (2235) panel grille must be ordered to accept an 83" (2108) or 88" (2235) custom panel. Width dimensions do not vary.



This design option allows for a flush door and grille. Stainless steel panels are available as sales accessories. Shown with tubular handle option to mirror Wolf built-in ovens.

Flush Inset Application

It is necessary to consider the following points when planning for a flush inset application:

- The flush inset depth is $2\frac{3}{16}$ " (56) deeper than the standard opening.
- The flush inset width is $2\frac{1}{2}$ " (64) wider than the standard opening.
- The flush inset height is $\frac{1}{4}$ " (6) higher than the standard opening.
- Panel widths increase to achieve the flush inset look.
- You must allow a $\frac{1}{2}$ " (13) reveal around the perimeter of the unit and grille to allow for proper door swing and airflow.

IMPORTANT NOTE: The flush inset application is not a separate model. This is an overlay unit in a flush installation. The same model is used in an overlay or flush inset application.

Rough opening dimensions for the flush inset application assume the use of a $\frac{3}{4}$ " (19) decorative panel. The illustrations below show the difference between standard and flush inset installations.

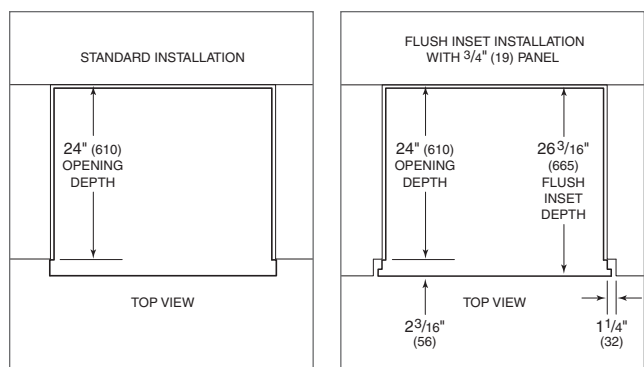

Standard installation.

Flush inset installation.

Built-In Models

FLUSH INSET INSTALLATION

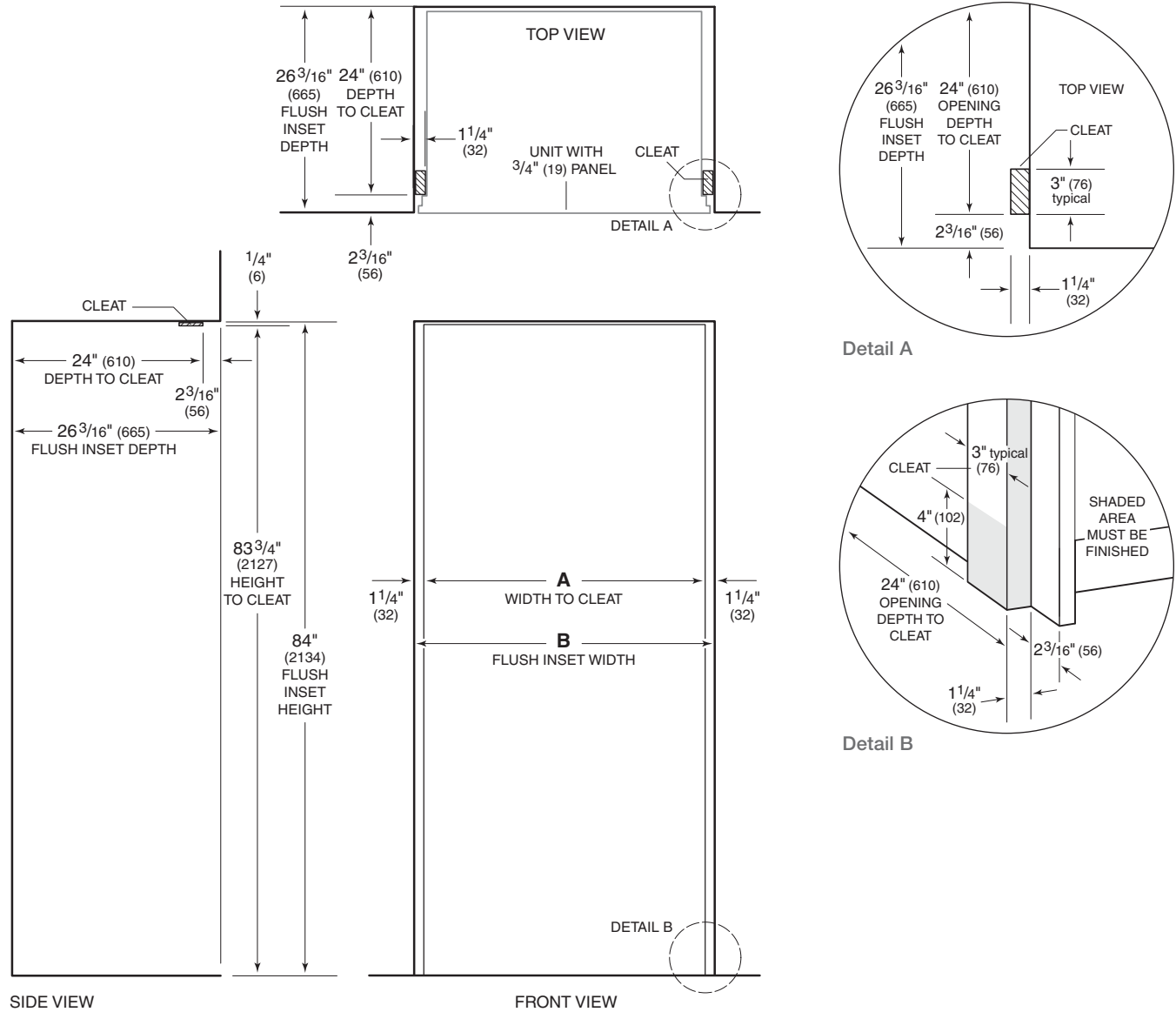

Flush Inset Opening Widths	A	B
BI-36R, BI-36RG and BI-36F	35 1/2" (902)	38" (965)
BI-30U and BI-30UG	29 1/2" (746)	32" (813)
BI-36U and BI-36UG	35 1/2" (902)	38" (965)
BI-36S	35 1/2" (902)	38" (965)
BI-42S and BI-42SD	41 1/2" (1054)	44" (1118)
BI-48S and BI-48SD	47 1/2" (1206)	50" (1270)

IMPORTANT NOTE: Dimensions assume a 3/4" (19) panel thickness.

IMPORTANT NOTE: If two units are installed side by side, refer to pages 32–36 for dual flush inset installations.

Flush Inset Panels

The flush inset application allows decorative panels on the front of the unit to be flush with surrounding cabinetry and is available for all built-in overlay models. For exact panel dimensions, refer to flush inset panel specifications on the following pages.

The flush inset design allows decorative panels to cover the door trim for a seamless appearance that blends with the design of the room. The most common way to achieve this look is to work with three panels—the decorative flush inset panel, which is typically 3/4" (19), a .10" (3) spacer panel and a 1/4" (6) backer panel. Depending on your cabinet manufacturer, this could also be one panel routed for different dimensions.

Regardless of the physical construction of the panels (three-panel assembly or routed panel), you will need to follow the flush inset panel specifications on the following pages for exact sizing and panel placement to ensure a proper fit.

⚠ CAUTION

Do not exceed flush inset panel dimensions, as this could cause damage to panels and the Sub-Zero unit.

Flush Inset Panel Requirements	
MAX WEIGHT PER PANEL	
BI-36R, BI-36RG and BI-36F	75 lbs (34 kg)
All Other Flush Inset Models	50 lbs (23 kg)
Grille Panel	13 lbs (6 kg)
MIN PANEL THICKNESS	
All Flush Inset Panels	5/8" (16)

The illustration below provides a rear view of the three-panel assembly with critical dimensions, standard for all built-in models.

IMPORTANT NOTE: The inside edges of the rough opening as well as the sides and a portion of the back side of the decorative panels will need to be finished, as they will be exposed when the doors are open.

IMPORTANT NOTE: On glass door models, the edges of the overlay, spacer and backer panels of the window cut-out will need to be finished, as they will be exposed.

IMPORTANT NOTE: For flush inset panels thicker than 3/4" (19), a 90° door stop may be required to prevent interference with adjacent cabinets. Refer to the full-scale templates at the end of this section.

IMPORTANT NOTE: When installing two units side by side in a flush inset application, refer to pages 32–36 for dual flush inset installations. Be aware that rough opening dimensions, panel sizes and offsets are different for this application.

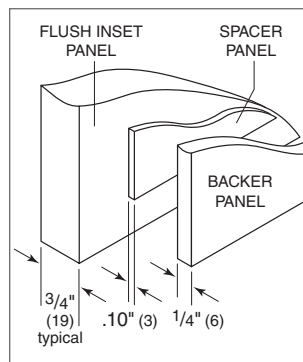

Three-panel assembly.

Flush Inset Panels

PANEL OFFSETS

Illustrations A–F provide panel offsets and reveals for all built-in models in a flush inset application. Refer to the chart below for reference to the illustrations relating to your specific model.

For additional information on model-specific panel reveals, visit the specification library section of our website, subzerotrade.com.

Panel Offsets	Illus.
ALL REFRIGERATOR / ALL FREEZER	
Door / Grille Sides	A
Grille Top	C
Grille Bottom / Door Top	D
Door Bottom	F
OVER-AND-UNDER	
Door / Drawer / Grille Sides	A
Grille Top	C
Grille Bottom / Door Top	D
Door Bottom / Drawer Top	E
Drawer Bottom	F
SIDE-BY-SIDE	
Doors (hinge) / Grille Sides	A
Doors (handle) Sides	B
Grille Top	C
Grille Bottom / Door Top	D
Door Bottom	F

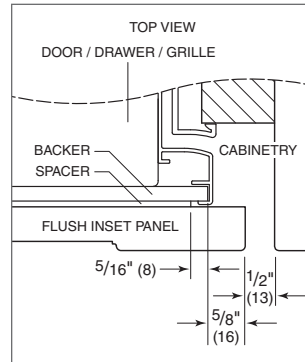

Illus. A

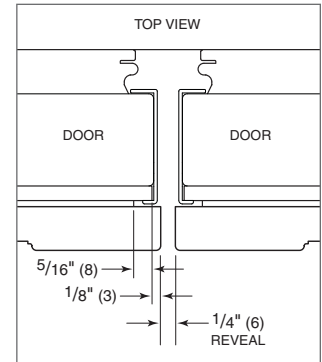

Illus. B

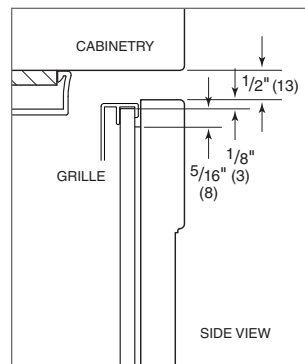

Illus. C

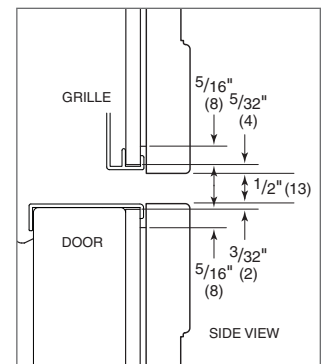

Illus. D

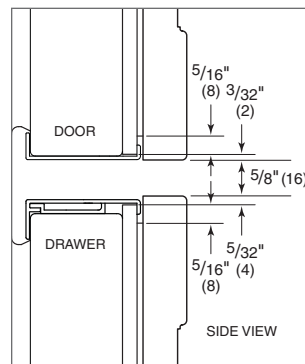

Illus. E

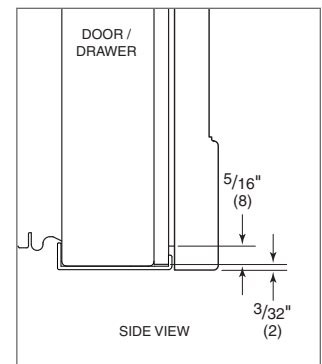

Illus. F

Flush Inset Panels

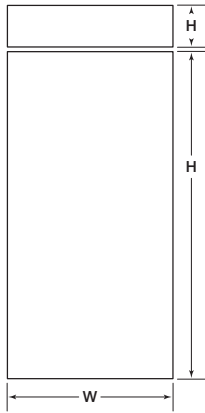

BI-36R / BI-36F

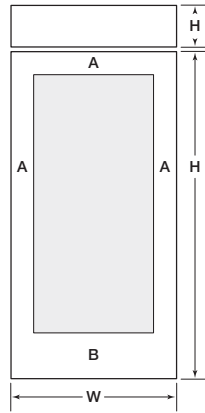

BI-36RG

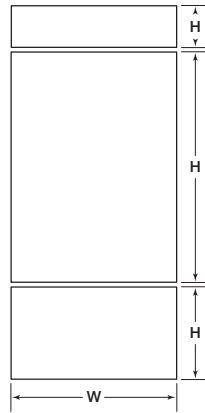

BI-30U / BI-36U

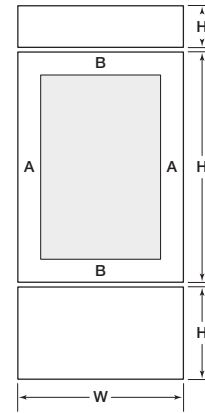

BI-30UG / BI-36UG

Models BI-36R, BI-36RG and BI-36F			
REFRIGERATOR / FREEZER	W	H	
Flush Inset Panel	37" (940)	69 ³ / ₄ " (1772)	
Spacer Panel	35 ¹ / ₈ " (892)	68 ¹⁵ / ₁₆ " (1751)	
Backer Panel	35 ³ / ₄ " (908)	69 ⁹ / ₁₆ " (1767)	
GRILLE	W	H	
Flush Inset Panel	37" (940)	9 ¹ / ₄ " (235)	
Spacer Panel	35 ¹ / ₈ " (892)	8 ⁵ / ₁₆ " (211)	
Backer Panel	35 ³ / ₄ " (908)	8 ¹⁵ / ₁₆ " (227)	
BI-36RG	W	H	
Window Cut-Out	25 ¹ / ₂ " (648)	54 ¹ / ₈ " (1375)	
	A	B	
Cut-Out Location	5 ³ / ₄ " (146)	10 ³ / ₈ " (264)	

Models BI-30U and BI-30UG			
REFRIGERATOR	W	H	
Flush Inset Panel	31" (787)	50 ¹ / ₈ " (1273)	
Spacer Panel	29 ¹ / ₈ " (740)	49 ⁵ / ₁₆ " (1253)	
Backer Panel	29 ³ / ₄ " (756)	49 ¹⁵ / ₁₆ " (1268)	
FREEZER	W	H	
Flush Inset Panel	31" (787)	19" (483)	
Spacer Panel	29 ¹ / ₈ " (740)	18 ¹ / ₁₆ " (459)	
Backer Panel	29 ³ / ₄ " (756)	18 ¹¹ / ₁₆ " (475)	
GRILLE	W	H	
Flush Inset Panel	31" (787)	9 ¹ / ₄ " (235)	
Spacer Panel	29 ¹ / ₈ " (740)	8 ⁵ / ₁₆ " (211)	
Backer Panel	29 ³ / ₄ " (756)	8 ¹⁵ / ₁₆ " (227)	
BI-30UG	W	H	
Window Cut-Out	19 ¹ / ₂ " (495)	39 ⁵ / ₈ " (1006)	
	A	B	
Cut-Out Location	5 ³ / ₄ " (146)	5 ¹ / ₄ " (133)	

Models BI-36U and BI-36UG			
REFRIGERATOR	W	H	
Flush Inset Panel	37" (940)	50 ¹ / ₈ " (1273)	
Spacer Panel	35 ¹ / ₈ " (892)	49 ⁵ / ₁₆ " (1253)	
Backer Panel	35 ³ / ₄ " (908)	49 ¹⁵ / ₁₆ " (1268)	
FREEZER	W	H	
Flush Inset Panel	37" (940)	19" (483)	
Spacer Panel	35 ¹ / ₈ " (892)	18 ¹ / ₁₆ " (459)	
Backer Panel	35 ³ / ₄ " (908)	18 ¹¹ / ₁₆ " (475)	
GRILLE	W	H	
Flush Inset Panel	37" (940)	9 ¹ / ₄ " (235)	
Spacer Panel	35 ¹ / ₈ " (892)	8 ⁵ / ₁₆ " (211)	
Backer Panel	35 ³ / ₄ " (908)	8 ¹⁵ / ₁₆ " (227)	
BI-36UG	W	H	
Window Cut-Out	25 ¹ / ₂ " (648)	39 ⁵ / ₈ " (1006)	
	A	B	
Cut-Out Location	5 ³ / ₄ " (146)	5 ¹ / ₄ " (133)	

Grille panel dimensions listed are for a standard 84" (2134) finished height. For an 83" (2108) finished height, subtract 1" (25) from grille panel height dimensions. For an 88" (2235) finished height, add 4" (102) to height dimensions. An 83" (2108) or 88" (2235) panel grille must be ordered to accept an 83" (2108) or 88" (2235) custom panel. Width dimensions do not vary.

Flush Inset Panels

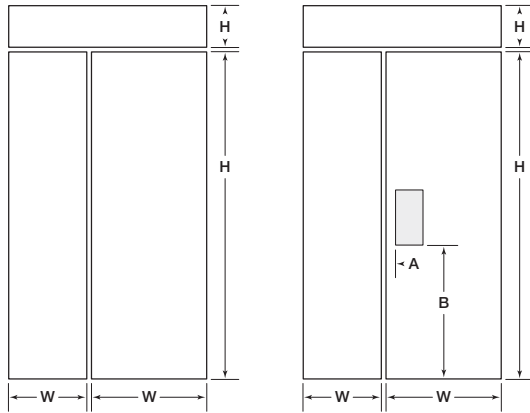

BI-36S / BI-42S / BI-48S BI-42SD / BI-48SD

Model BI-36S			
	W	H	
REFRIGERATOR			
Flush Inset Panel	20 ⁹ / ₁₆ " (522)	69 ³ / ₄ " (1772)	
Spacer Panel	19 ³ / ₁₆ " (487)	68 ¹⁵ / ₁₆ " (1751)	
Backer Panel	19 ¹³ / ₁₆ " (503)	69 ⁹ / ₁₆ " (1767)	
FREEZER			
Flush Inset Panel	16 ³ / ₁₆ " (411)	69 ³ / ₄ " (1772)	
Spacer Panel	14 ¹³ / ₁₆ " (376)	68 ¹⁵ / ₁₆ " (1751)	
Backer Panel	15 ⁷ / ₁₆ " (392)	69 ⁹ / ₁₆ " (1767)	
GRILLE			
Flush Inset Panel	37" (940)	9 ¹ / ₄ " (235)	
Spacer Panel	35 ¹ / ₈ " (892)	8 ⁵ / ₁₆ " (211)	
Backer Panel	35 ³ / ₄ " (908)	8 ¹⁵ / ₁₆ " (227)	

Models BI-42S and BI-42SD			
	W	H	
REFRIGERATOR			
Flush Inset Panel	25 ⁹ / ₁₆ " (649)	69 ³ / ₄ " (1772)	
Spacer Panel	24 ³ / ₁₆ " (614)	68 ¹⁵ / ₁₆ " (1751)	
Backer Panel	24 ¹³ / ₁₆ " (630)	69 ⁹ / ₁₆ " (1767)	
FREEZER			
Flush Inset Panel	17 ³ / ₁₆ " (437)	69 ³ / ₄ " (1772)	
Spacer Panel	15 ¹³ / ₁₆ " (402)	68 ¹⁵ / ₁₆ " (1751)	
Backer Panel	16 ⁷ / ₁₆ " (418)	69 ⁹ / ₁₆ " (1767)	
GRILLE			
Flush Inset Panel	43" (1092)	9 ¹ / ₄ " (235)	
Spacer Panel	41 ¹ / ₈ " (1045)	8 ⁵ / ₁₆ " (211)	
Backer Panel	41 ³ / ₄ " (1060)	8 ¹⁵ / ₁₆ " (227)	
DISPENSER (BI-42SD)			
Dispenser Cut-Out	5 ⁷ / ₈ " (149)	12 ⁷ / ₁₆ " (316)	
	A	B	
Cut-Out Location	2" (51)	28 ¹³ / ₁₆ " (732)	

Models BI-48S and BI-48SD			
	W	H	
REFRIGERATOR			
Flush Inset Panel	29 ¹ / ₄ " (743)	69 ³ / ₄ " (1772)	
Spacer Panel	27 ⁷ / ₈ " (708)	68 ¹⁵ / ₁₆ " (1751)	
Backer Panel	28 ¹ / ₂ " (724)	69 ⁹ / ₁₆ " (1767)	
FREEZER			
Flush Inset Panel	19 ¹ / ₂ " (495)	69 ³ / ₄ " (1772)	
Spacer Panel	18 ¹ / ₈ " (460)	68 ¹⁵ / ₁₆ " (1751)	
Backer Panel	18 ³ / ₄ " (476)	69 ⁹ / ₁₆ " (1767)	
GRILLE			
Flush Inset Panel	49" (1245)	9 ¹ / ₄ " (235)	
Spacer Panel	47 ¹ / ₈ " (1197)	8 ⁵ / ₁₆ " (211)	
Backer Panel	47 ³ / ₄ " (1213)	8 ¹⁵ / ₁₆ " (227)	
DISPENSER (BI-48SD)			
Cut-Out	5 ⁷ / ₈ " (149)	12 ⁷ / ₁₆ " (316)	
	A	B	
Cut-Out Location	2" (51)	28 ¹³ / ₁₆ " (732)	

Grille panel dimensions listed are for a standard 84" (2134) finished height. For an 83" (2108) finished height, subtract 1" (25) from grille panel height dimensions. For an 88" (2235) finished height, add 4" (102) to height dimensions. An 83" (2108) or 88" (2235) panel grille must be ordered to accept an 83" (2108) or 88" (2235) custom panel. Width dimensions do not vary.

Dispenser

MODELS BI-42SD AND BI-48SD

The refrigerator door panel must include a cut-out to accommodate the dispenser glasswell and bezel. The thickness of the panel in this area can range from $\frac{1}{4}$ " (6) to a maximum of $1\frac{1}{8}$ " (29).

IMPORTANT NOTE: Regardless of the thickness of the panel for model BI-42SD or BI-48SD, you must plan for a flat landing area for the decorative bezel surrounding the glasswell area. The illustration to the right provides exact bezel dimensions. Refer to the appropriate panel specifications page for exact cut-out location. This landing area can be accomplished in a number of different ways. These photos show two options.

One option (flush) is to rout the panel so the bezel will be flush with rails and stiles. You must rout a space to accommodate the height and width of the bezel. The width of the stile immediately to the left of the bezel must be $1\frac{3}{4}$ " (44). Do not cut the entire stile to this dimension.

The other option (proud) shows a boxed out landing area for the bezel using stiles and rails to create this space. In this application, the bezel will sit proud of the stiles and rails. The total thickness of the panels at this level must not exceed $1\frac{1}{8}$ " (29).

For overlay and flush inset models, mounting placement of the refrigerator door handle must assure proper access to the glasswell and adequate clearance under the handle.

The handle placement illustration shows the relation of the refrigerator door handle to the glasswell bezel on stainless steel models.

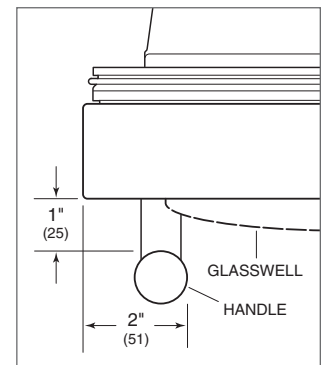
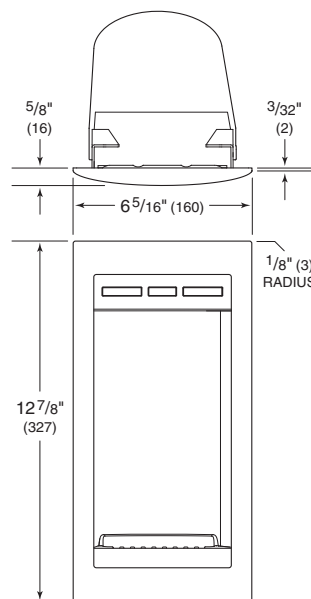

Handle placement.

Dispenser dimensions.



Flush option.



Proud option.

Side Panels

Side panels can be used with every design application. When planning for side panels with the installation of a built-in model, you need to be aware of the space configuration to achieve a pleasing fit. Depending on the exact panel you are using with your unit, the height of the panel may vary.

IMPORTANT NOTE: The use of side panels may change the width of your rough opening.

The side panel will need to be a minimum of 24" (610) deep and 1/2" (13) thick. Refer to the illustrations below for side panel dimensions. Routing will be necessary so that the side panel fits flush against the side of the unit.

IMPORTANT NOTE: If you have a model BI-30U, BI-30UG, BI-36U or BI-36UG, extra routing will be necessary to prevent the panel from hitting the refrigerator lower hinge plate.

When installing a built-in unit with a custom side panel, an accessory kit (7003407) is required. Stainless steel and white enamel side panels are also available through your authorized Sub-Zero dealer.

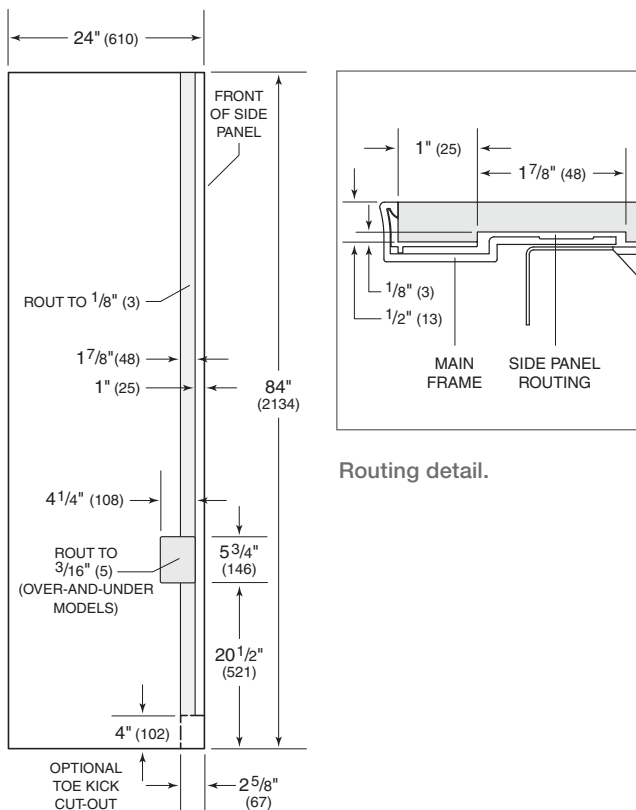

Side panel dimensions.



Dual installation—standard application.

Dual Installation

STANDARD APPLICATION

Two overlay or stainless steel units may be placed side by side in a dual installation. Some standard applications will require a dual installation kit, available through your authorized Sub-Zero dealer. If you are installing two units side by side in a flush inset application, refer to page 32.

A custom filler strip can be used between two units in a framed, overlay or stainless steel design application. It is recommended that the filler strip be at least 2" (51) wide to prevent condensation between the units. Be sure to add the filler strip width to your rough opening width. Refer to the full-scale template on page 42.

Dual installations without a filler strip can only be accomplished using two units with opposite hinges as shown in illustration A below. The dual installations shown in illustrations B and C require a filler strip.

IMPORTANT NOTE: For the application shown in illustration A, a dual installation accessory kit is required. Refer to page 36 for information on dual installation kits.

Dual Installation Panel Requirements	
MAX WEIGHT PER PANEL	
BI-36R, BI-36RG and BI-36F	75 lbs (34 kg)
All Other Models	50 lbs (23 kg)
Dual Wide Grille Panel	26 lbs (12 kg)
MIN PANEL THICKNESS	
Framed Panels	1/4" (6)
Overlay and Flush Inset Panels	5/8" (16)

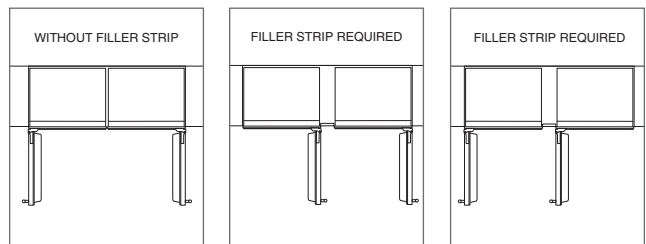

Illus. A

Illus. B

Illus. C

Dual Installation

STANDARD INSTALLATION

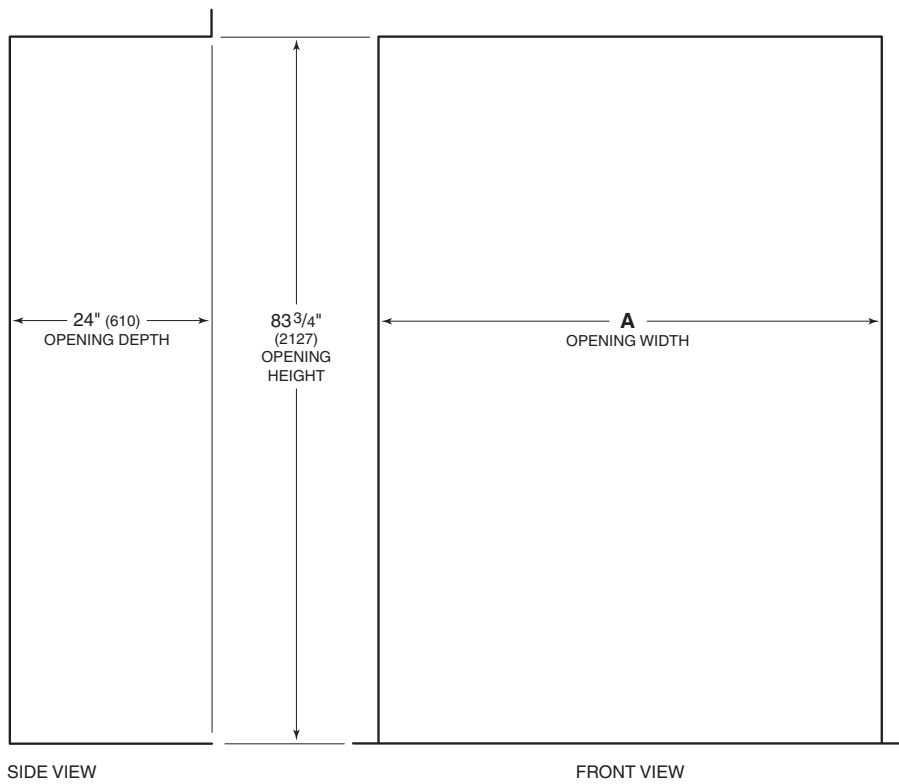
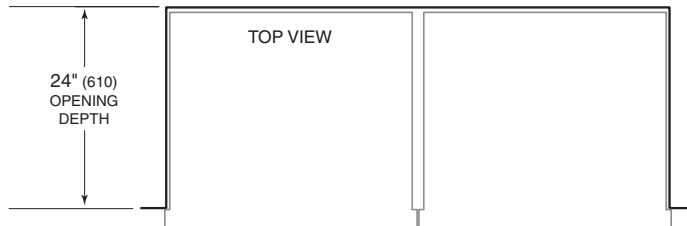

Opening Widths	A
Two 30" (762) Models	59 ³ / ₄ " (1518)
30" (762) and 36" (914) Models	65 ³ / ₄ " (1670)
Two 36" (914) Models	71 ³ / ₄ " (1822)

IMPORTANT NOTE: A dual installation kit will be required for this installation.

Stainless steel models are ready to install out of the box.



Dual installation—flush inset application.

Dual Installation Panel Requirements	
MAX WEIGHT PER PANEL	
BI-36R, BI-36RG and BI-36F	75 lbs (34 kg)
All Other Models	50 lbs (23 kg)
Dual Wide Grille Panel	26 lbs (12 kg)
MIN PANEL THICKNESS	
Flush Inset Panels	5/8" (16)

Dual Installation

FLUSH INSET APPLICATION

Installing two built-in models side by side in a flush inset application will require adjustments to the dimensions of your finished rough opening, panel sizes and panel offsets. It will also require a dual installation kit, available through your authorized Sub-Zero dealer.

Dual installations without a filler strip can only be accomplished using two units with opposite hinges as shown in illustration A below. The dual installations shown in illustrations B and C require a filler strip. Refer to the full-scale template on page 43. Illustration A is the only application that will accommodate the dual wide grille.

IMPORTANT NOTE: The application shown in illustration A can only be achieved by installing dual flush inset panels. Failure to install dual flush inset panels will cause the handle side of the panels to collide when closing. In this application a dual installation accessory kit is also required.

Dual flush inset panels and dual installation kits are available through your authorized Sub-Zero dealer. Refer to pages 34–35 for dual flush inset panel specifications and page 36 for information on dual installation kits.

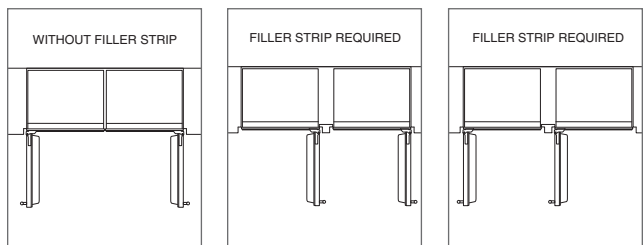

Illus. A

Illus. B

Illus. C

Dual Installation

FLUSH INSET INSTALLATION

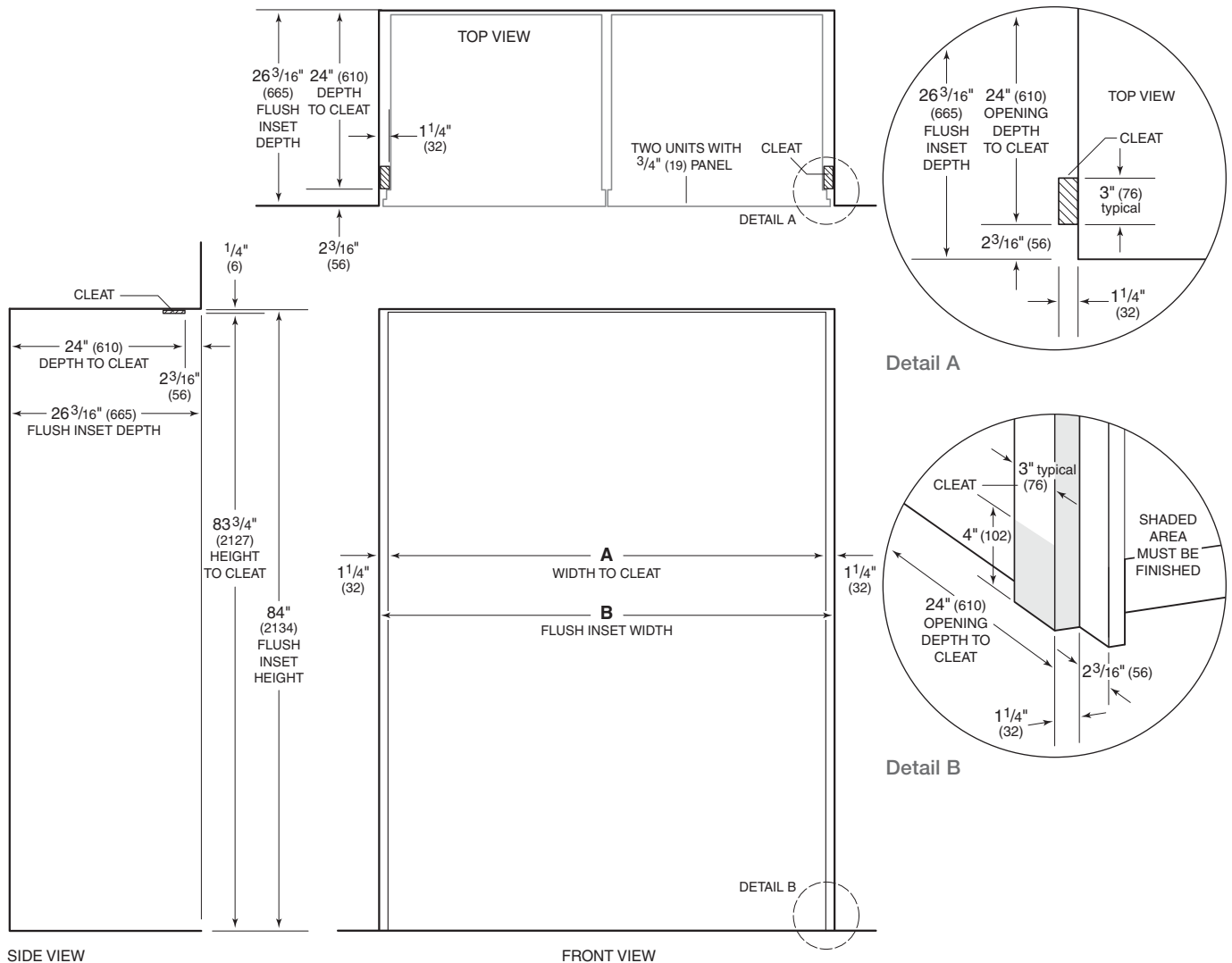

Opening Widths	A	B
Two 30" (762) Models	59 ³ / ₄ " (1518)	62 ¹ / ₄ " (1581)
30" (762) and 36" (914) Models	65 ³ / ₄ " (1670)	68 ¹ / ₄ " (1734)
Two 36" (914) Models	71 ³ / ₄ " (1822)	74 ¹ / ₄ " (1886)

IMPORTANT NOTE: Dimensions assume a $\frac{3}{4}$ " (19) panel thickness. A dual installation kit will be required for this installation.

Dual Installation

FLUSH INSET PANEL OFFSETS

When installing two built-in models side by side in a flush inset application, you must decrease the width of the decorative flush inset panels by 1/2" (13). Adjustments to the panel offsets will also need to be made. These adjustments are needed to achieve a proper fit and to ensure the panels do not collide when closing. Panel dimensions in the chart below have been adjusted to reflect the decrease in panel dimensions.

IMPORTANT NOTE: If a filler strip is not used, dual installations can only be accomplished using two units with opposite hinges.

Illustrations A–F provide panel offsets and reveals for all built-in models in a flush inset application. Refer to the chart below for reference to the illustrations relating to your specific model. All reveals are 1/2" (13) unless otherwise specified.

For additional information on model-specific panel reveals, visit the specification library section of our website, subzerotrade.com.

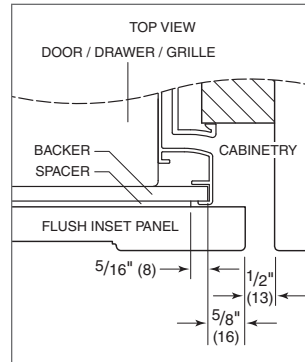

Illus. A

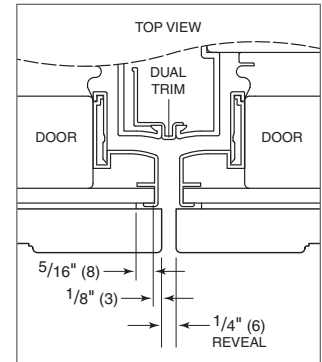

Illus. B

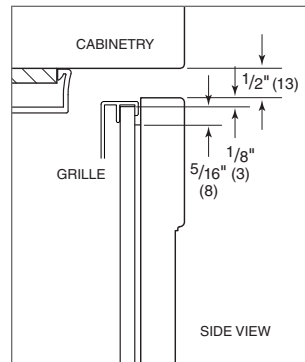

Illus. C

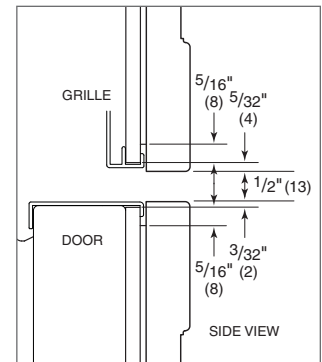

Illus. D

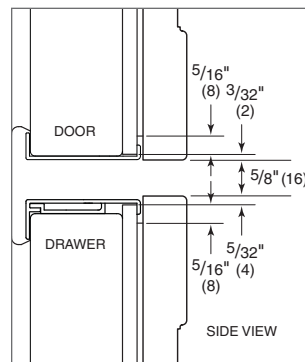

Illus. E

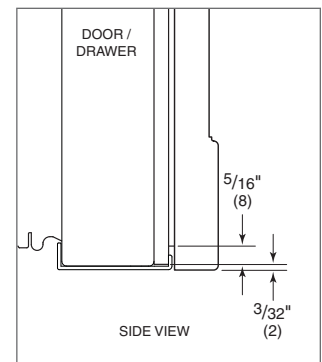

Illus. F

Panel Offsets	Illus.
ALL REFRIGERATOR / ALL FREEZER	
Doors (hinge) / Grille Sides	A
Doors (handle) Sides	B
Grille Top	C
Grille Bottom / Door Top	D
Door Bottom	F
OVER-AND-UNDER	
Doors (hinge) / Drawer / Grille Sides	A
Doors (handle) Sides	B
Grille Top	C
Grille Bottom / Door Top	D
Door Bottom / Drawer Top	E
Drawer Bottom	F

CAUTION
Do not exceed flush inset panel dimensions, as this could cause damage to panels and the Sub-Zero unit.

Dual Installation—Flush Inset Panels

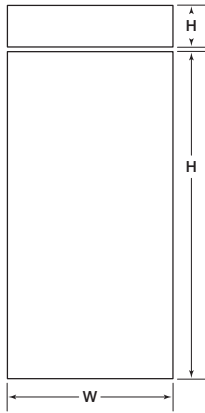

BI-36R / BI-36F

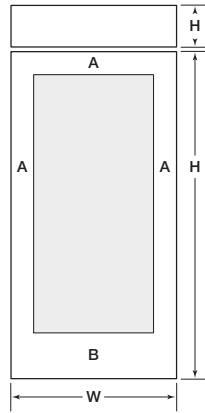

BI-36RG

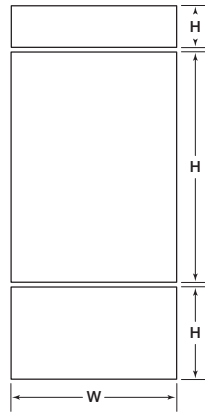

BI-30U / BI-36U

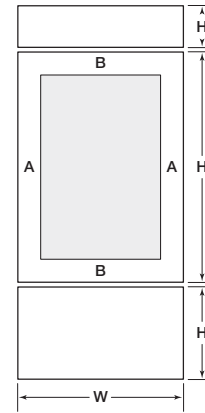

BI-30UG / BI-36UG

BI-36R, BI-36RG and BI-36F			
REFRIGERATOR / FREEZER	W	H	
Flush Inset Panel	36 ¹ / ₂ " (927)	69 ³ / ₄ " (1772)	
Spacer Panel	35 ¹ / ₈ " (892)	68 ¹⁵ / ₁₆ " (1751)	
Backer Panel	35 ³ / ₄ " (908)	69 ⁹ / ₁₆ " (1767)	
GRILLE	W	H	
Flush Inset Panel	36 ¹ / ₂ " (927)	9 ¹ / ₄ " (235)	
Spacer Panel	35 ¹ / ₈ " (892)	8 ⁵ / ₁₆ " (211)	
Backer Panel	35 ³ / ₄ " (908)	8 ¹⁵ / ₁₆ " (227)	
BI-36RG	W	H	
Window Cut-Out	25" (635)	54 ¹ / ₈ " (1375)	
	A	B	
Cut-Out Location	5 ³ / ₄ " (146)	10 ³ / ₈ " (264)	

BI-30U and BI-30UG			
REFRIGERATOR	W	H	
Flush Inset Panel	30 ¹ / ₂ " (775)	50 ¹ / ₈ " (1273)	
Spacer Panel	29 ¹ / ₈ " (740)	49 ⁵ / ₁₆ " (1253)	
Backer Panel	29 ³ / ₄ " (756)	49 ¹⁵ / ₁₆ " (1268)	
FREEZER	W	H	
Flush Inset Panel	30 ¹ / ₂ " (775)	19" (483)	
Spacer Panel	29 ¹ / ₈ " (740)	18 ¹ / ₁₆ " (459)	
Backer Panel	29 ³ / ₄ " (756)	18 ¹¹ / ₁₆ " (475)	
GRILLE	W	H	
Flush Inset Panel	30 ¹ / ₂ " (775)	9 ¹ / ₄ " (235)	
Spacer Panel	29 ¹ / ₈ " (740)	8 ⁵ / ₁₆ " (211)	
Backer Panel	29 ³ / ₄ " (756)	8 ¹⁵ / ₁₆ " (227)	
BI-30UG	W	H	
Window Cut-Out	19" (483)	39 ⁵ / ₈ " (1006)	
	A	B	
Cut-Out Location	5 ³ / ₄ " (146)	5 ¹ / ₄ " (133)	

BI-36U and BI-36UG			
REFRIGERATOR	W	H	
Flush Inset Panel	36 ¹ / ₂ " (927)	50 ¹ / ₈ " (1273)	
Spacer Panel	35 ¹ / ₈ " (892)	49 ⁵ / ₁₆ " (1253)	
Backer Panel	35 ³ / ₄ " (908)	49 ¹⁵ / ₁₆ " (1268)	
FREEZER	W	H	
Flush Inset Panel	36 ¹ / ₂ " (927)	19" (483)	
Spacer Panel	35 ¹ / ₈ " (892)	18 ¹ / ₁₆ " (459)	
Backer Panel	35 ³ / ₄ " (908)	18 ¹¹ / ₁₆ " (475)	
GRILLE	W	H	
Flush Inset Panel	36 ¹ / ₂ " (927)	9 ¹ / ₄ " (235)	
Spacer Panel	35 ¹ / ₈ " (892)	8 ⁵ / ₁₆ " (211)	
Backer Panel	35 ³ / ₄ " (908)	8 ¹⁵ / ₁₆ " (227)	
BI-36UG	W	H	
Window Cut-Out	25" (635)	39 ⁵ / ₈ " (1006)	
	A	B	
Cut-Out Location	5 ³ / ₄ " (146)	5 ¹ / ₄ " (133)	

Grille panel dimensions listed are for a standard 84" (2134) finished height. For an 83" (2108) finished height, subtract 1" (25) from grille panel height dimensions. For an 88" (2235) finished height, add 4" (102) to height dimensions. Width dimensions do not vary.

For dual wide grilles, refer to page 36.

Dual Installation Kit

INSTALLATION WITH DUAL WIDE GRILLE

This kit will replace the existing grilles that ship with the units and span the entire width of both units. The kit includes a 1/4" (6) center trim strip (required for proper installation of the dual wide grille), heater, dual kickplate and mounting hardware. Dual wide grilles are available for all built-in models and design applications. The overlay dual installation kit with grille will accept overlay and dual flush inset panels. For dual wide grille panel dimensions, refer to the panel specifications below for your design application. Grille panel dimensions listed are for a standard 84" (2134) finished height.

Dual Wide Grille—Overlay		
TWO 30" (762) MODELS	W	H
Overlay Panel	60 1/4" (1530)	9 1/4" (235)
Spacer Panel	59 3/8" (1508)	8 5/16" (211)
Backer Panel	60" (1524)	8 15/16" (227)
30" (762) AND 36" (914) MODELS	W	H
Overlay Panel	66 1/4" (1683)	9 1/4" (235)
Spacer Panel	65 3/8" (1661)	8 5/16" (211)
Backer Panel	66" (1676)	8 15/16" (227)
TWO 36" (914) MODELS	W	H
Overlay Panel	72 1/4" (1835)	9 1/4" (235)
Spacer Panel	71 3/8" (1813)	8 5/16" (211)
Backer Panel	72" (1829)	8 15/16" (227)

Dual Wide Grille—Flush Inset		
TWO 30" (762) MODELS	W	H
Flush Inset Panel	61 1/4" (1556)	9 1/4" (235)
Spacer Panel	59 3/8" (1508)	8 5/16" (211)
Backer Panel	60" (1524)	8 15/16" (227)
30" (762) AND 36" (914) MODELS	W	H
Flush Inset Panel	67 1/4" (1708)	9 1/4" (235)
Spacer Panel	65 3/8" (1661)	8 5/16" (211)
Backer Panel	66" (1676)	8 15/16" (227)
TWO 36" (914) MODELS	W	H
Flush Inset Panel	73 1/4" (1861)	9 1/4" (235)
Spacer Panel	71 3/8" (1813)	8 5/16" (211)
Backer Panel	72" (1829)	8 15/16" (227)

INSTALLATION WITH INDIVIDUAL GRILLES

This kit is available for those who choose to utilize the individual grilles that ship with each unit. The kit includes a 1/4" (6) filler strip (which fills the reveal between the units and grilles), heater and mounting hardware. This dual installation kit is not required if a custom filler strip is used. The filler strip should be a minimum of 2" (51) wide. Refer to the full-scale template on page 42 for more information.

Accessories

These optional accessories are available through your authorized Sub-Zero dealer. For local dealer information, visit the find a showroom section of our website, subzero.com.

- Flush inset front panels in stainless steel with handle options.
- Framed front panels in stainless steel and white enamel.
- Side panels in stainless steel and white enamel.
- Grilles for an 83" (2108) or 88" (2235) finished height.
- Extended framed handles.
- Tubular and pro handles to match the style of Wolf ovens and ranges.
- Dual installation kits with and without dual wide grille.
- Retrofit kits for use with 600 series panels.
- Partial framed kit for dispenser models.

STANDARD HANDLE LENGTHS

Refer to the chart below for standard lengths of tubular, and pro handles used on built-in models.

Standard Handle Lengths		
ALL REFRIGERATOR / ALL FREEZER AND SIDE-BY-SIDE	DOOR	
Tubular Handle	63 ⁷ / ₈ " (1622)	
Pro Handle	45 ¹ / ₈ " (1146)	
Stud Spacing	43 ⁷ / ₈ " (1114)	
BI-30U AND BI-30UG	DOOR	DRAWER
Tubular Handle	44 ¹ / ₄ " (1124)	24 ⁵ / ₁₆ " (633)
Pro Handle	37 ¹ / ₂ " (952)	21" (533)
Stud Spacing	36 ¹ / ₄ " (921)	16 ⁵ / ₁₆ " (414)
BI-36U AND BI-36UG	DOOR	DRAWER
Tubular Handle	44 ¹ / ₄ " (1124)	30 ⁵ / ₁₆ " (770)
Pro Handle	37 ¹ / ₂ " (952)	23 ¹ / ₂ " (597)
Stud Spacing	36 ¹ / ₄ " (921)	22 ⁵ / ₁₆ " (567)

Framed Panel Thickness

FULL-SCALE TEMPLATE

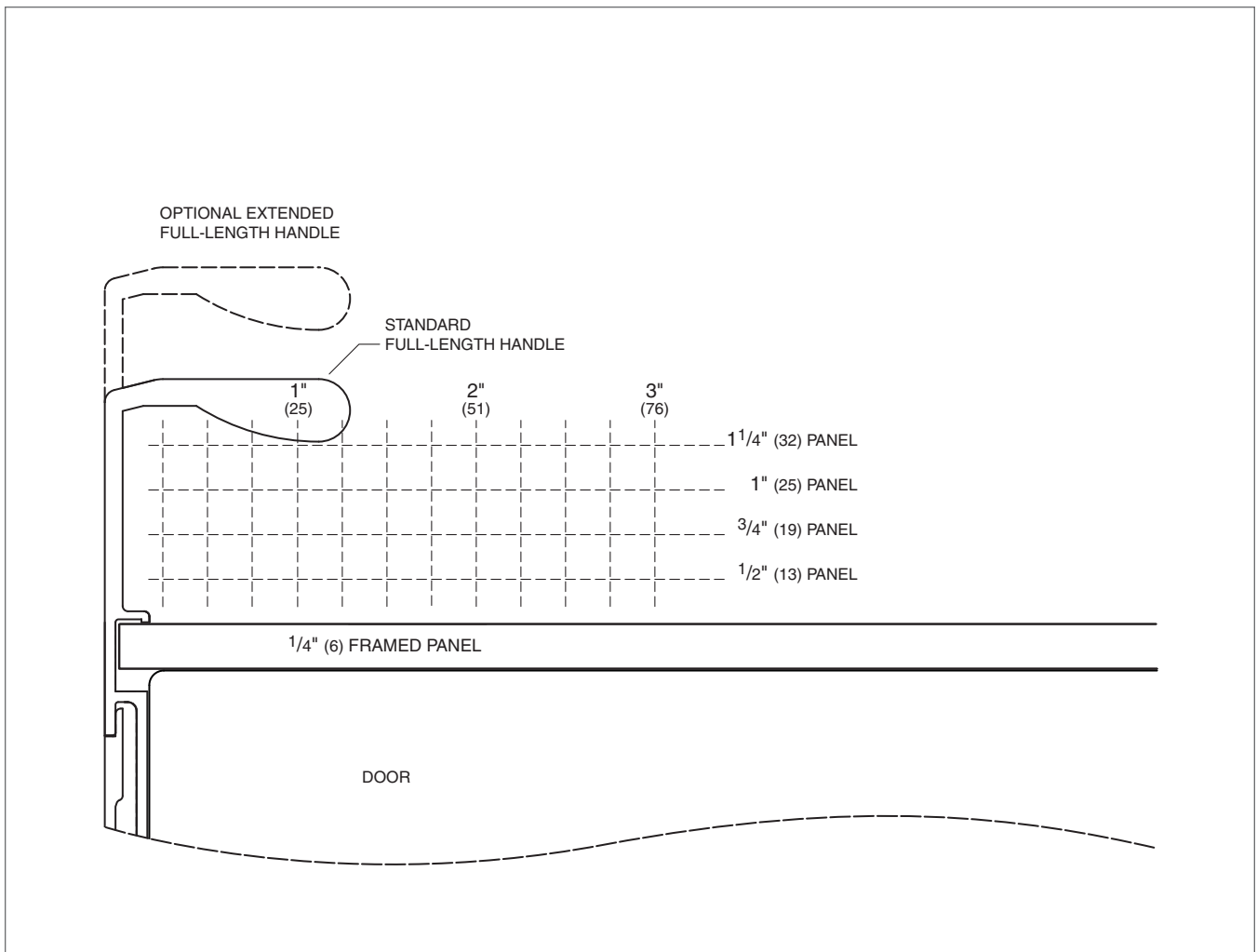

PANEL THICKNESS
FRAMED APPLICATION

Overlay Panel Thickness

FULL-SCALE TEMPLATE

Overlay and flush inset panels must be a minimum of $\frac{5}{8}$ " (16) thick to support mounting the handle. Panel thickness does not include backer and spacer panel. Mount handle close to the opening edge of the door.

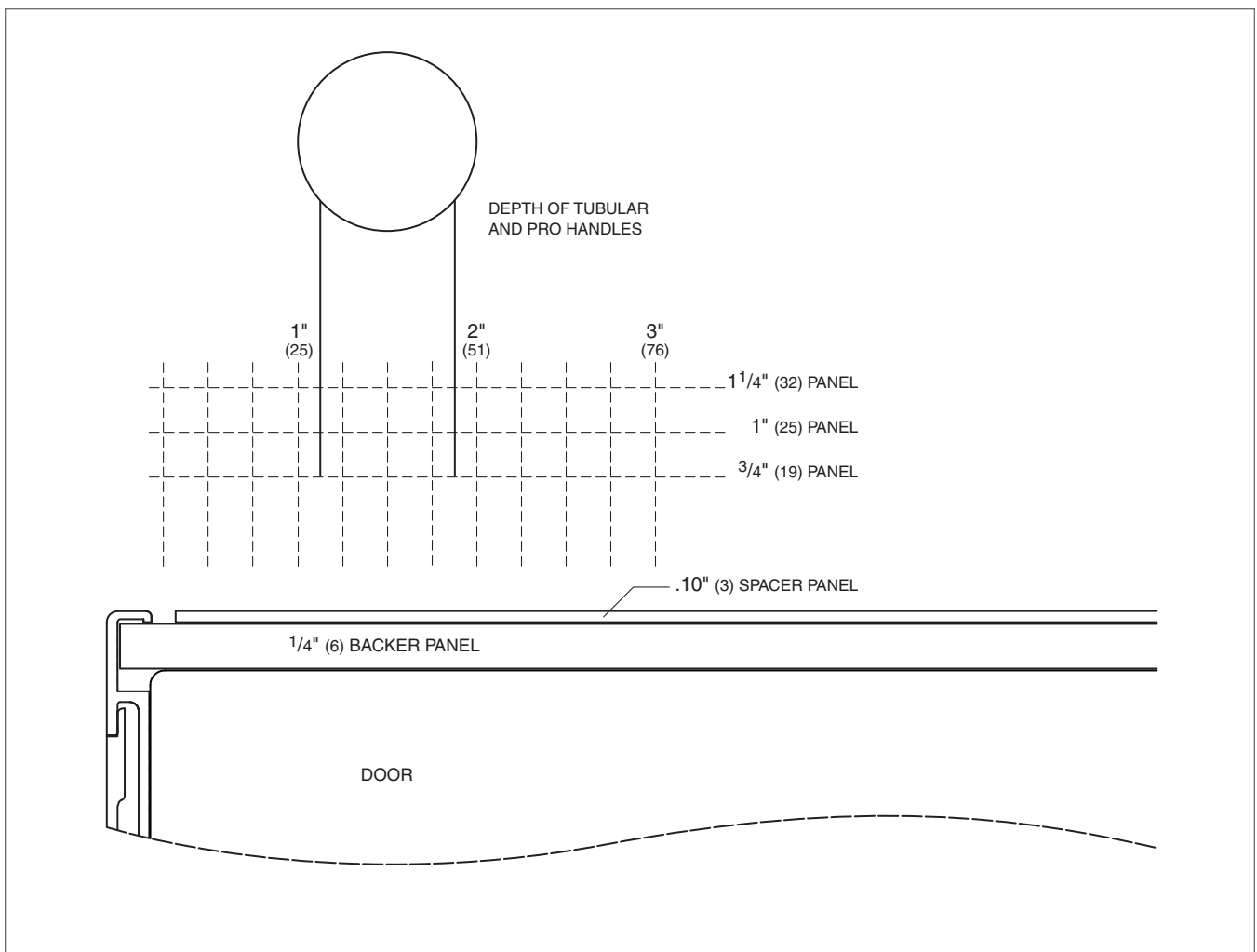

PANEL THICKNESS

OVERLAY AND FLUSH INSET APPLICATIONS

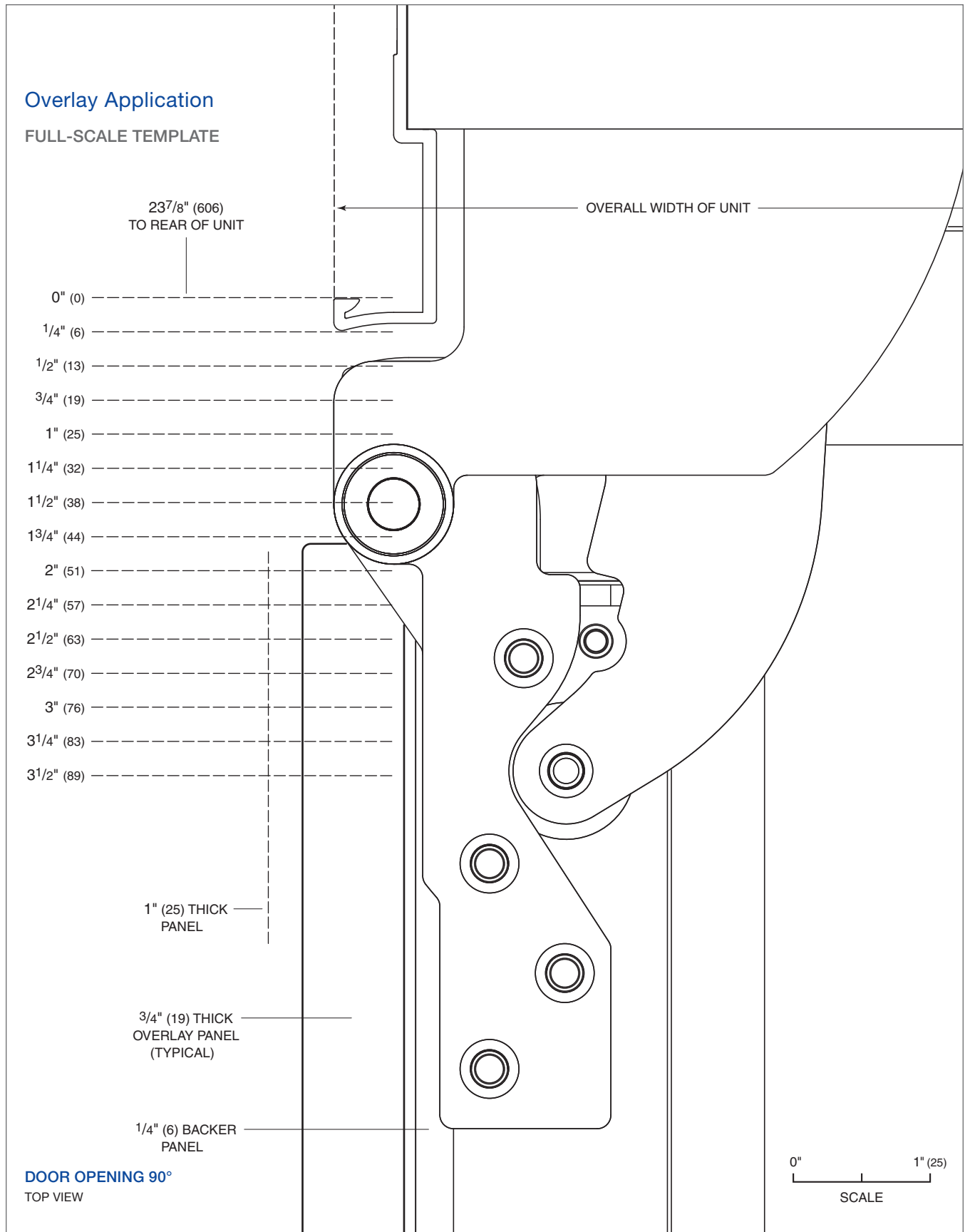

Flush Inset Application

FULL-SCALE TEMPLATE

For panels thicker than 3/4" (19), a 90° door stop may be required to prevent interference with adjacent cabinets.

24" (610)
TO BACK WALL

1 1/4" (32)

2 3/16" (56)
ASSUMES
3/4" (19)
FLUSH INSET
PANEL
THICKNESS

1" (25) THICK
PANEL

3/4" (19) THICK
FLUSH INSET PANEL
(TYPICAL)

1/4" (6) BACKER
PANEL

DOOR OPENING 110°
TOP VIEW

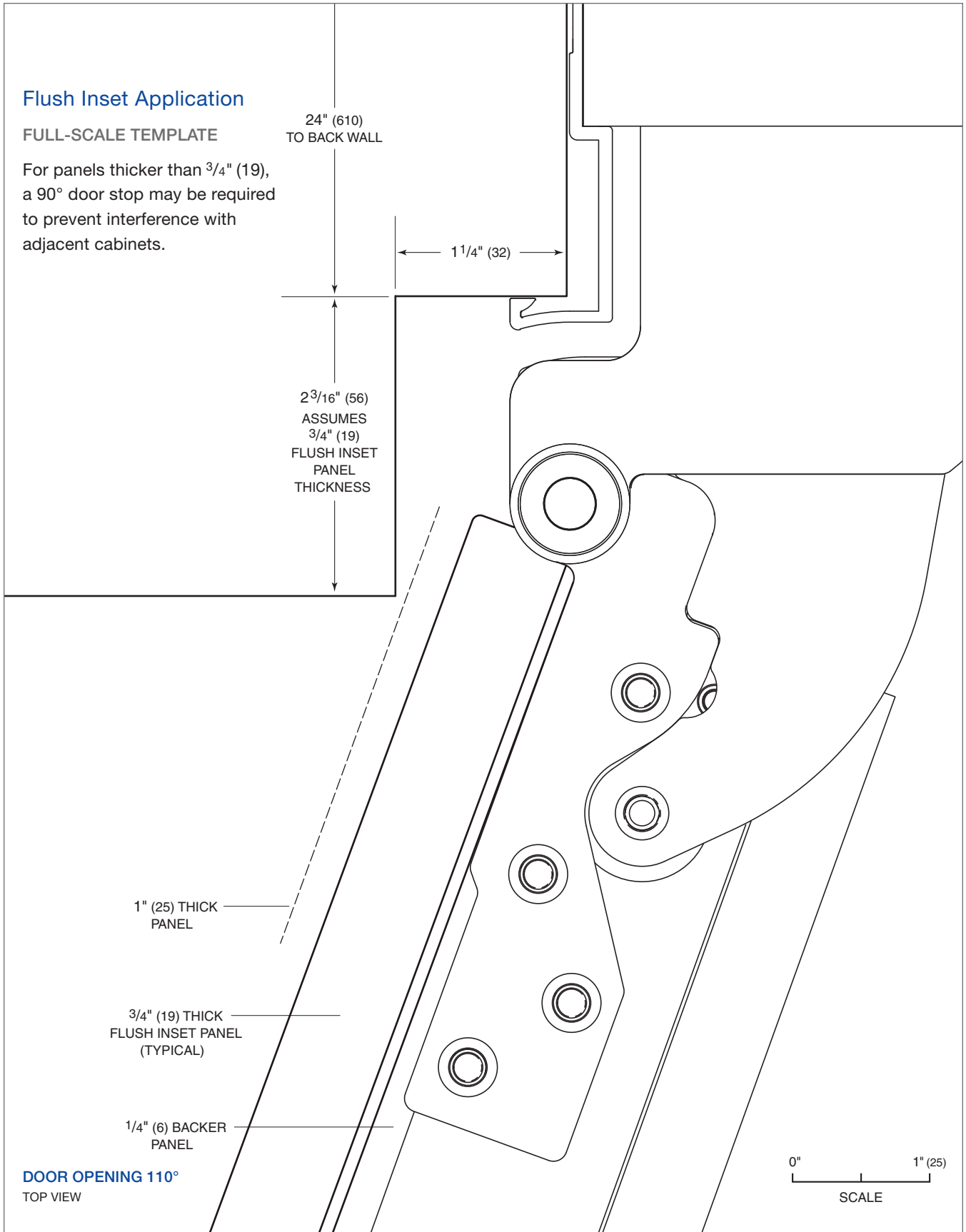
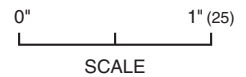

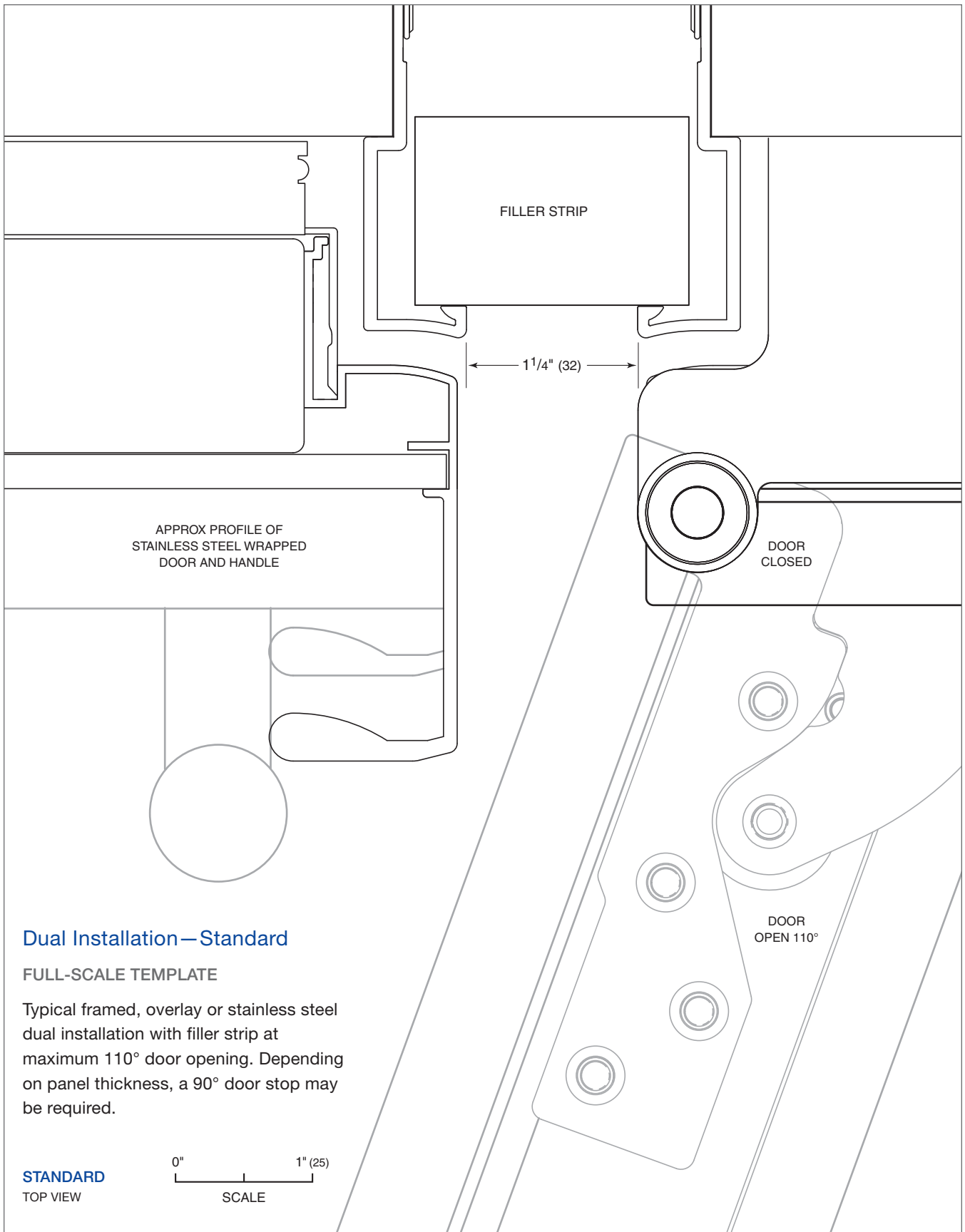

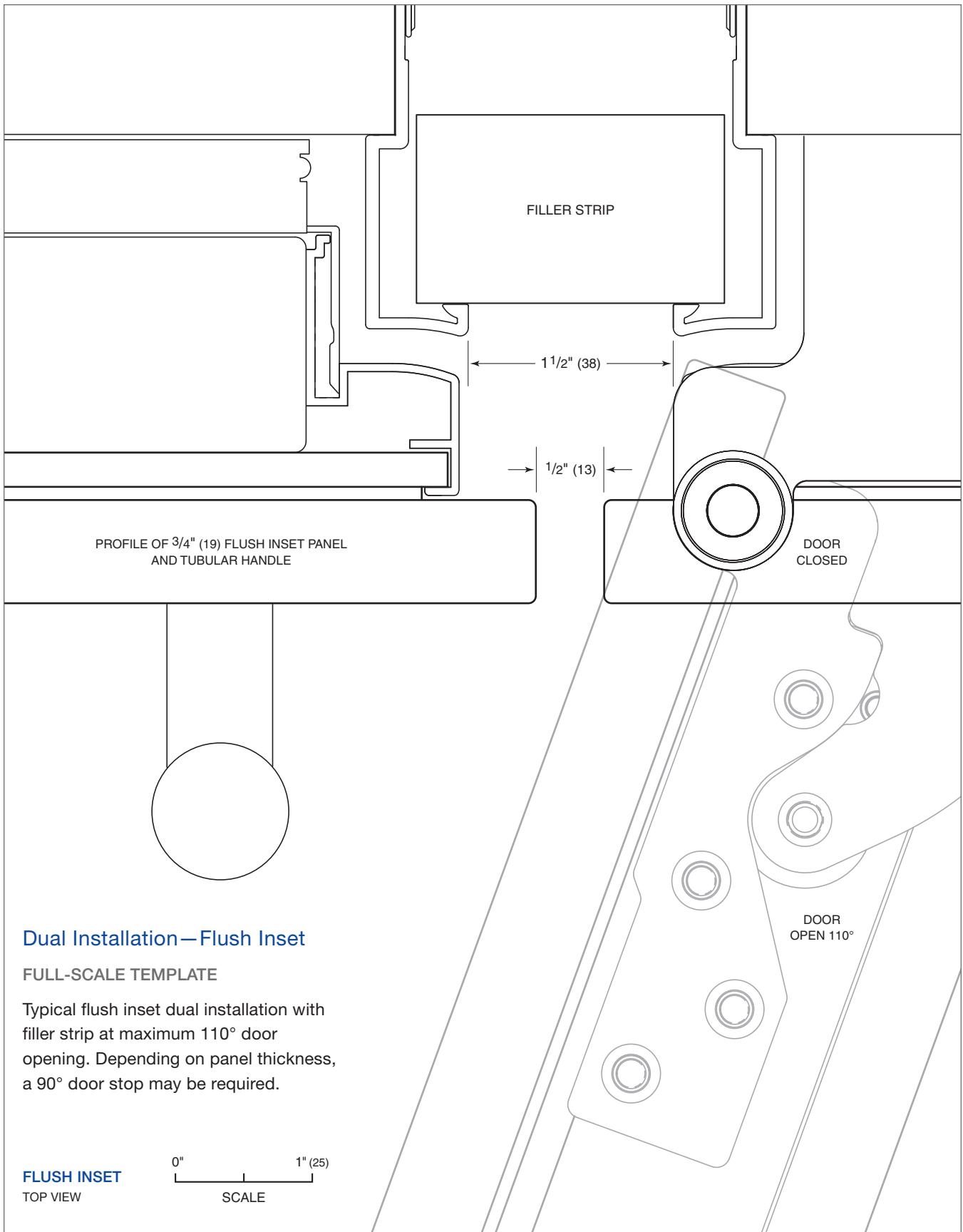

Dual Installation—Flush Inset

FULL-SCALE TEMPLATE

Typical flush inset dual installation with filler strip at maximum 110° door opening. Depending on panel thickness, a 90° door stop may be required.



MODEL 648PRO

PRO 48 Refrigeration. Freshness finds unmistakable expression in the Sub-Zero PRO 48. An 800-pound monument to food preservation—equal parts sculpted metal design statement and culinary secret weapon. Its vast interior, like its bold exterior, is crafted of stainless steel. The PRO 48 is available with or without a glass door and may be either built in or freestanding.

PRO 48 MODELS

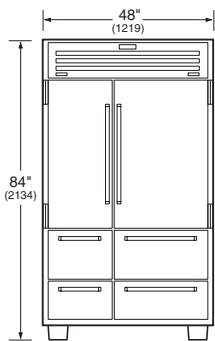

648PRO

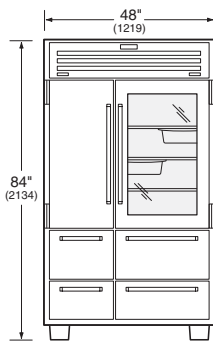

648PROG

KEY FEATURES

- Can be used freestanding or installed as a standard or flush built-in application.
- Handles coordinate with handles of Wolf ranges.
- Stainless steel interior as well as exterior.
- Dual refrigeration system enhanced with triple evaporators allow independent control of storage conditions in refrigerator cabinet and drawer compartments.
- Advanced water filtration system.
- Exterior temperature display.
- Flip-up grille provides easy access for quick routine maintenance.
- Star-K certified.

PRO 48 Models

OVERALL DIMENSIONS

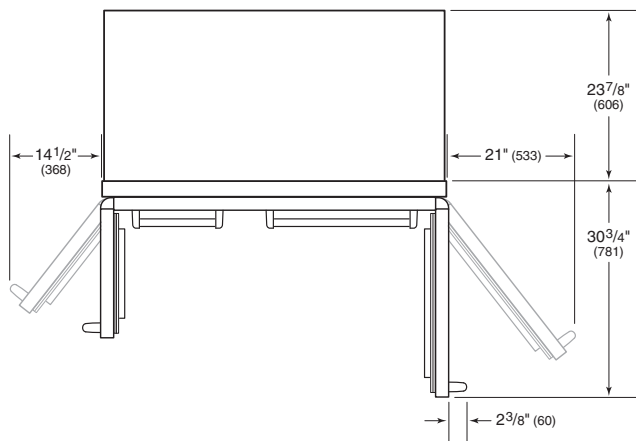
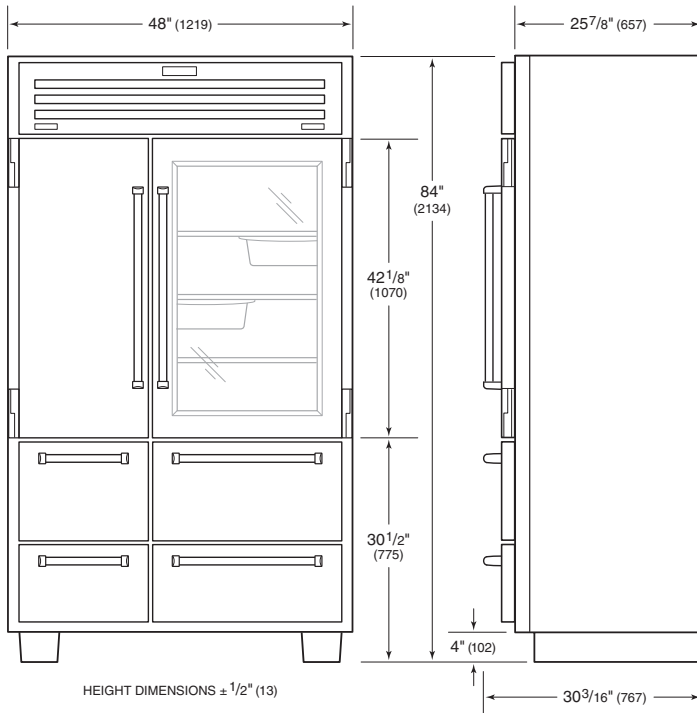

SPECIFICATIONS

Capacity / Weight		
INTERIOR CAPACITY	R CU FT (L)	F CU FT (L)
648PRO and 648PROG	18.4 (521)	11.7 (331)
SHIPPING WEIGHT		LBS (KG)
648PRO		860 (390)
648PROG		875 (397)

MODELS 648PRO AND 648PROG

PRO 48 Models

STANDARD AND FLUSH BUILT-IN INSTALLATIONS

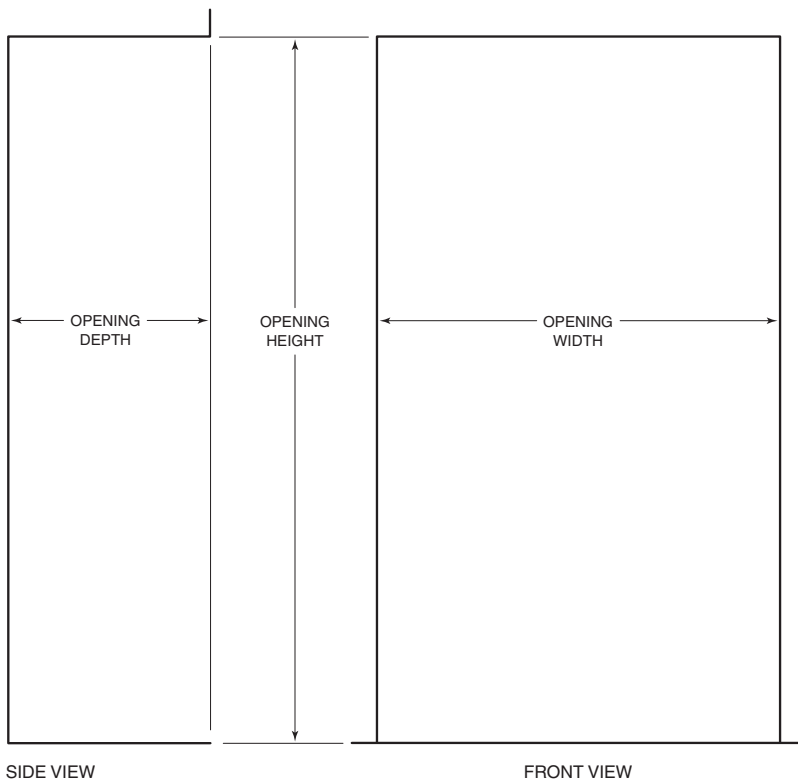
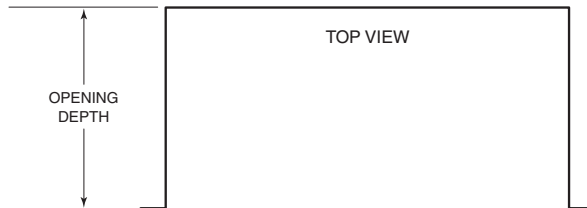

Opening Dimensions	Standard	Flush
Opening Width	47 1/2" (1206)	48" (1219)
Opening Height	83 3/4" (2127)	84 1/8" (2137)
Opening Depth	24" (610)	26" (660)

IMPORTANT NOTE: For standard built-in installations, the face frame of the unit will extend 2" (51) beyond cabinetry. In flush built-in installations, the front of the face frame will be flush with surrounding cabinetry.

Planning Information

PRO 48 models can be used freestanding or installed as a standard or flush built-in application. For standard built-in installations, the face frame of the unit will extend 2" (51) beyond cabinetry. In flush built-in installations, the front of the face frame will be flush with surrounding cabinetry.

ELECTRICAL REQUIREMENTS

For PRO 48 models, the electrical supply should be located within the shaded area shown in the illustration below. Follow the National Electrical Code and local codes and ordinances when installing the receptacle. A separate circuit, servicing only this appliance, is required. A ground fault circuit interrupter (GFCI) is not recommended and may cause interruption of operation.

Electrical Requirements	
Power Supply	115 V AC, 60 Hz
Circuit Breaker	15 amp
Receptacle	3-prong grounding-type

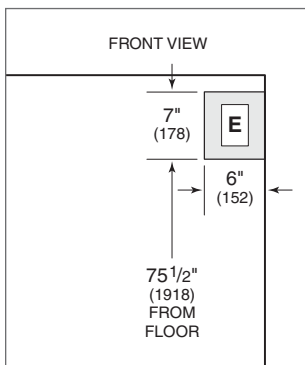

Location of electrical supply.

PLUMBING REQUIREMENTS

PRO 48 models come with an automatic ice maker and an integrated water filtration system. The water supply line should be located within the shaded area shown in the illustration below. The water supply line should be connected to the house supply with an easily accessible shut-off valve between the supply and the unit. Do not use self-piercing valves. A saddle valve kit (4200880) is available through your authorized Sub-Zero dealer. The water line must not interfere with installation of the anti-tip brackets.

IMPORTANT NOTE: A reverse osmosis system can be used provided there is constant water pressure of 35 psi (2.4 bar) to 120 psi (8.3 bar) supplied to the unit at all times. In this application, the integrated water filtration system must be set to bypass mode. This is achieved by removing the water filter cartridge. Refer to the PRO 48 installation guide packed with the unit for detailed instructions.

Plumbing Requirements	
Water Supply Line	1/4" OD copper line
Water Pressure	35–120 psi (2.4–8.3 bar)
Excess Water Line for Connection	36" (914)

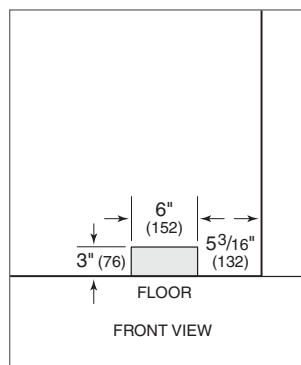

Location of water supply.

Accessories

These optional accessories are available through your authorized Sub-Zero dealer. For local dealer information, visit the find a showroom section of our website, subzero.com.

- Freestanding kit, which contains two stainless steel side panels and top lid.
- Stainless steel side panel.
- Refrigerator drawer dividers for compartmentalized storage.
- Stainless steel slide-out refrigerator bin.
- Dozen egg container.
- 90° door stop.



MODELS IC-27F, 427G (WINE) AND IC-27R

Integrated Refrigeration. With custom cabinet fronts and hardware, Sub-Zero invented integrated columns, drawers and tall units that disappear into the decor. Integrated units fit flush with other cabinets, making integrated refrigeration as practical and beautiful in the master suite, bar or theatre room as in the kitchen.

INTEGRATED MODELS

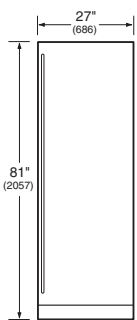

IC-27R
AVAILABLE
2ND QUARTER 2010

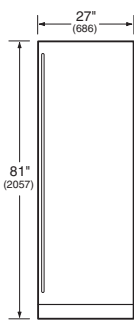

IC-27FI
AVAILABLE
2ND QUARTER 2010

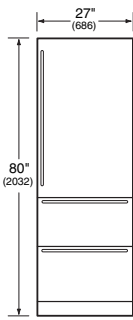

700TR

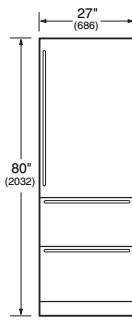

700TFI

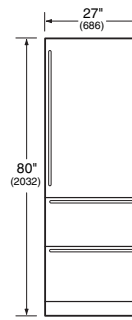

700TCI

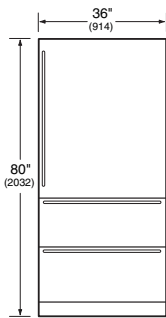

736TR

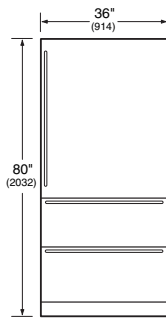

736TFI

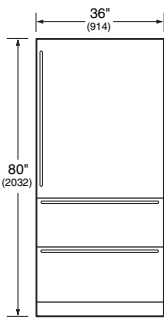

736TCI

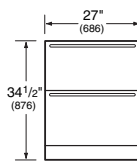

700BR

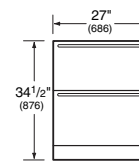

700BF(I)

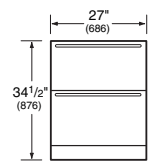

700BC(I)

KEY FEATURES

- Custom cabinet fronts and hardware allow for infinite design options.
- Point-of-use refrigeration that can be placed anywhere in the home.
- Dual refrigeration; two compressors preserve food's goodness in self-contained compartments.
- Energy efficient; many models are ENERGY STAR® qualified.
- Drawer models are Star-K certified.

Overall Dimensions

COLUMN MODELS

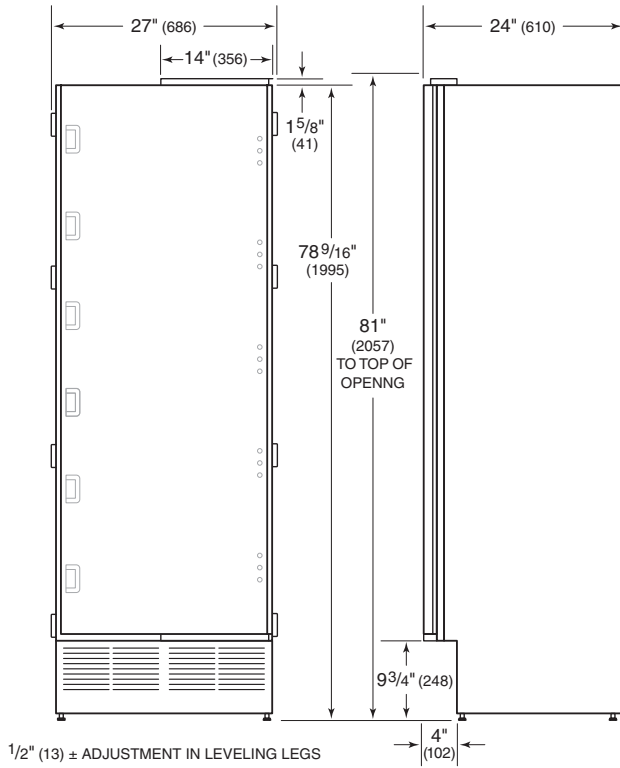

27" (686) TALL MODELS

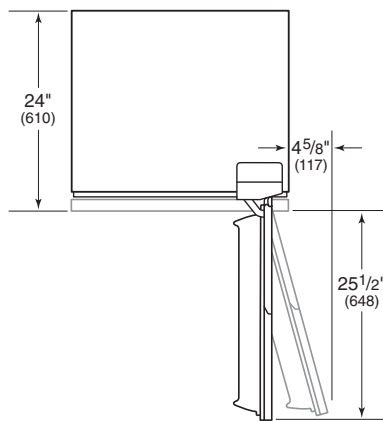
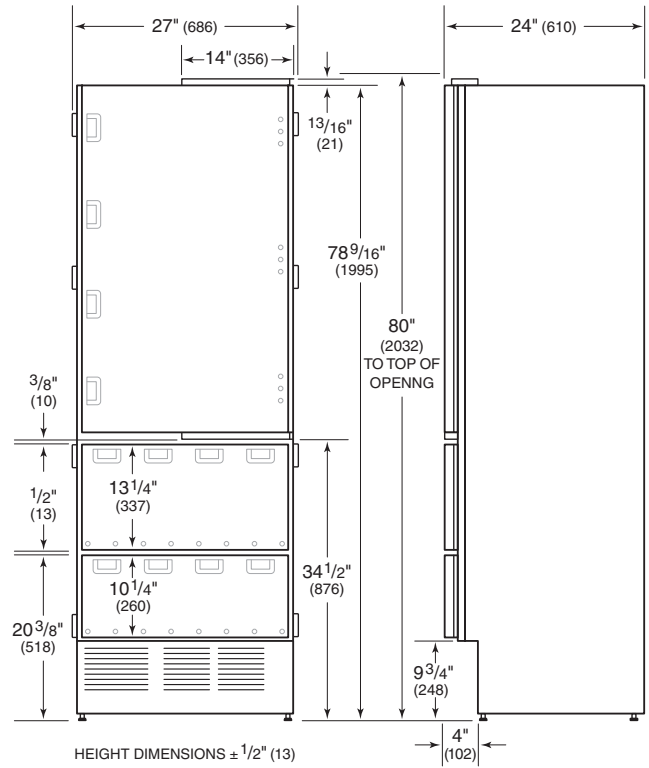

DIMENSIONS WILL VARY WITH PANEL THICKNESS

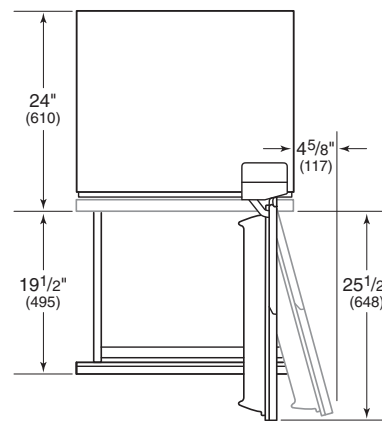

DIMENSIONS WILL VARY WITH PANEL THICKNESS

MODELS IC-27R AND IC-27FI

MODELS 700TR, 700TFI AND 700TCI

Overall dimensions do not include panels or handles.

Overall Dimensions

36" (914) TALL MODELS

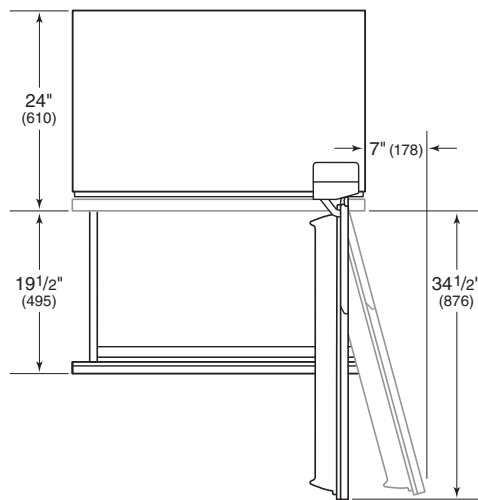
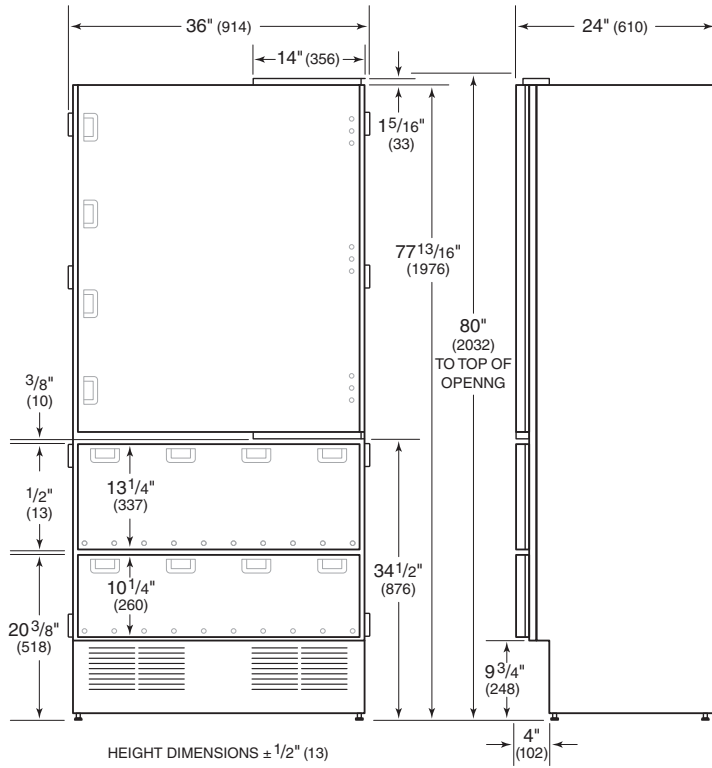

DIMENSIONS WILL VARY WITH PANEL THICKNESS

MODELS 736TR, 736TFI AND 736TCI

Overall Dimensions

DRAWER MODELS

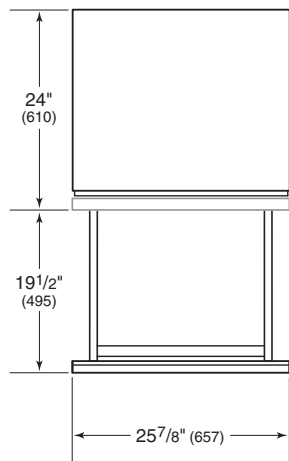
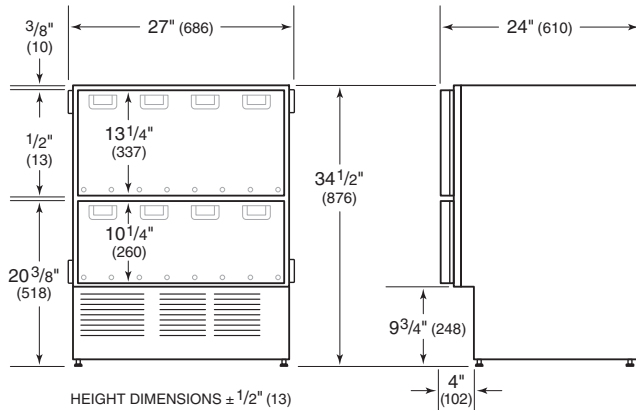

DIMENSIONS WILL VARY WITH PANEL THICKNESS

MODELS 700BR, 700BF(I) AND 700BC(I)

Capacity and Weight

Interior Capacity	R cu ft (L)	F cu ft (L)
COLUMN MODELS		
IC-27R	16.2 (459)	
IC-27FI		16.3 (462)
27" (686) TALL MODELS		
700TR	15.5 (439)	
700TFI		15.3 (433)
700TCI	10.2 (289)	5.1 (144)
36" (914) TALL MODELS		
736TR	20.9 (592)	
736TFI		21.5 (609)
736TCI	13.3 (377)	7.1 (201)
27" (686) DRAWER MODELS		
700BR	5.3 (150)	
700BF(I)		5.1 (144)
700BC(I)	2.9 (82)	2.1 (59)

Shipping Weight	lbs (kg)
IC-27R, IC-27FI, 700TR, 700TFI and 700TCI	360 (163)
736TR, 736TFI and 736TCI	480 (218)
700BR, 700BF(I) and 700BC(I)	190 (86)

Opening Dimensions

INTEGRATED MODELS

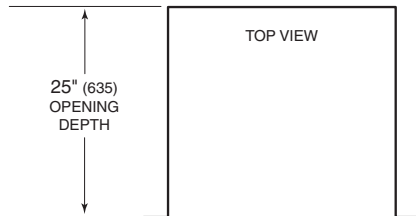

IMPORTANT NOTE: The depth of each integrated model is 24" (610) from the front of the unit to its back. Your design may necessitate moving the unit back or cabinets forward to achieve a flush fit. This will require a minimum rough opening depth of 25" (635).

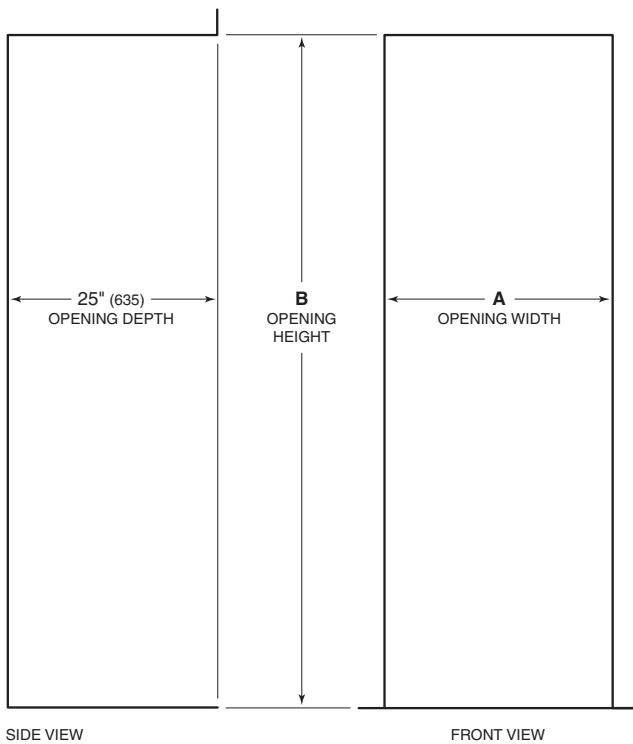

Opening Dimensions	A	B
IC-27R and IC-27FI	27" (686)	81" (2057)
700TR, 700TFI, 700TCI	27" (686)	80" (2032)
736TR, 736TFI, 736TCI	36" (914)	80" (2032)
700BR, 700BF(I), 700BC(I)	27" (686)	34 ¹ / ₂ " (876)

Electrical Requirements

The electrical supply should be located within the shaded area shown in the illustrations. Follow the National Electrical Code and local codes and ordinances when installing the receptacle. A separate circuit, servicing only this appliance, is required. A ground fault circuit interrupter (GFCI) is not recommended and may cause interruption of operation.

IMPORTANT NOTE: It is critical that the electrical outlet be located within the shaded area shown so it does not interfere with installation of the anti-tip bracket. It must be flush with the back wall and positioned with the grounding prong to the right of the thinner blades.

Electrical Requirements	
Power Supply	115 V AC, 60 Hz
Circuit Breaker	15 amp
Receptacle	3-prong grounding-type

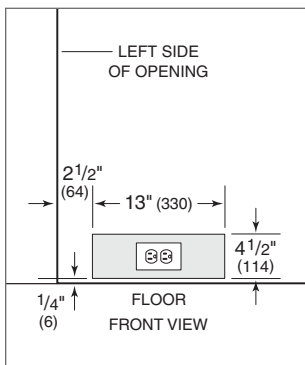

27" (686) models.

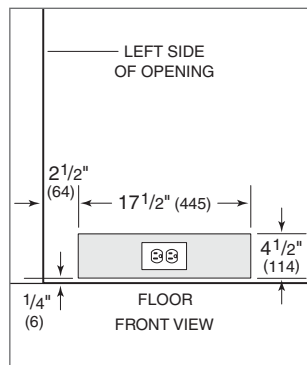

36" (914) models.

Plumbing Requirements

For integrated models with an automatic ice maker, the water supply line should be located through the floor or back wall, within the shaded area shown in the illustrations. The water supply line should be connected to the house supply with an easily accessible shut-off valve between the supply and the unit. Do not use self-piercing valves. A saddle valve kit (4200880) is available through your authorized Sub-Zero dealer.

IMPORTANT NOTE: It is critical that the water line be located within the shaded area shown so it does not interfere with installation of the anti-tip bracket.

An in-line filter is required when water conditions have a high sediment content. The ice maker operates on constant water pressure between 20 psi (1.4 bar) and 100 psi (6.9 bar).

IMPORTANT NOTE: In some cases, a reverse osmosis water filter system may not be able to maintain the minimum pressure consistently.

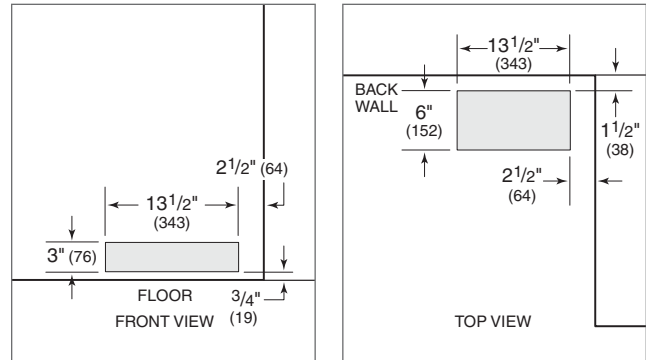

36" (914) models.

Plumbing Requirements	
Water Supply Line	1/4" OD copper line
Water Pressure	20–100 psi (1.4–6.9 bar)
Excess Water Line for Connection	27" (686)

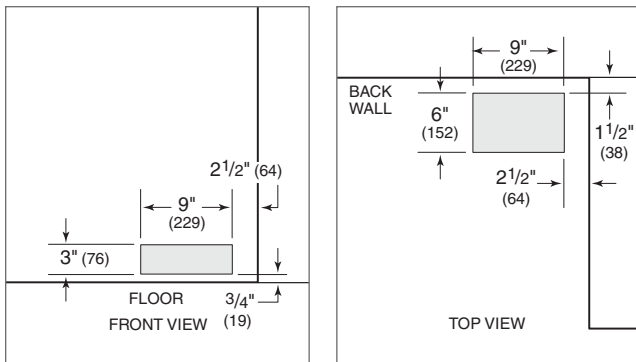

27" (686) models.

Cabinetry Applications

FRAMELESS CABINERY

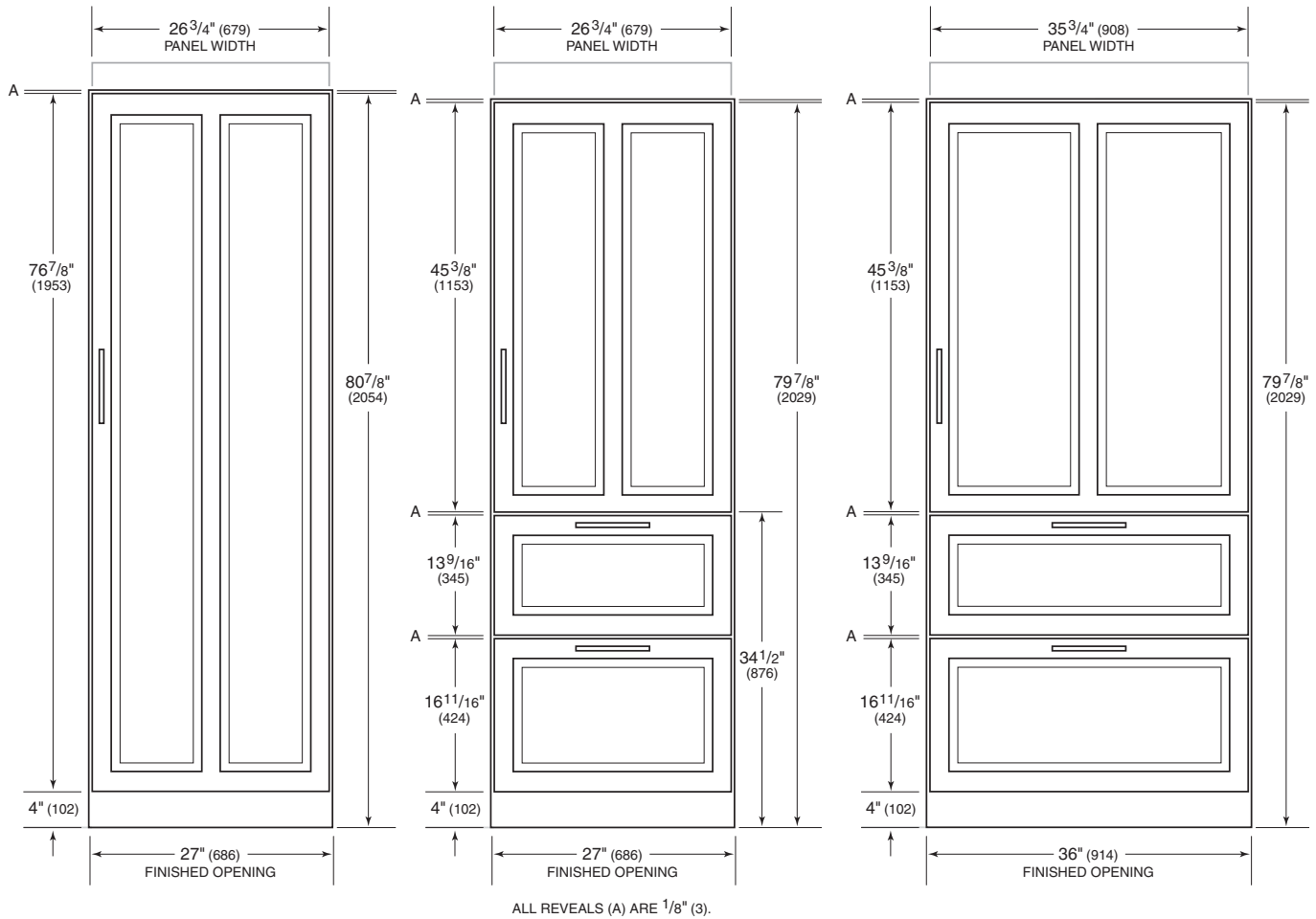

COLUMN MODELS

27" (686) MODELS

TALL AND DRAWER MODELS

36" (914) MODELS

TALL MODELS

Typical Panel Dimensions		
COLUMN MODELS		
Door	W 26 ³ / ₄ " (679)	H 76 ⁷ / ₈ " (1953)
27" (686) MODELS		
Door	W 26 ³ / ₄ " (679)	H 45 ³ / ₈ " (1153)
Top Drawer	W 26 ³ / ₄ " (679)	H 13 ⁹ / ₁₆ " (345)
Bottom Drawer	W 26 ³ / ₄ " (679)	H 16 ¹¹ / ₁₆ " (424)
36" (914) MODELS		
Door	W 35 ³ / ₄ " (908)	H 45 ³ / ₈ " (1153)
Top Drawer	W 35 ³ / ₄ " (908)	H 13 ⁹ / ₁₆ " (345)
Bottom Drawer	W 35 ³ / ₄ " (908)	H 16 ¹¹ / ₁₆ " (424)

Panel dimensions are based on a 1/8" (3) reveal. A reveal of up to 1/4" (6) is possible with adjustments to panel dimensions.

Cabinetry Applications

DOOR PANEL HEIGHT

The height of the door panel can extend beyond the typical panel height, provided you do not exceed the panel weight limit. The illustration below shows how the panel may be extended and what you need to consider to finish the area behind the door panel.

IMPORTANT NOTE: The decorative valance used to finish the area behind the door panel must stay behind the front plane of the finished molding.

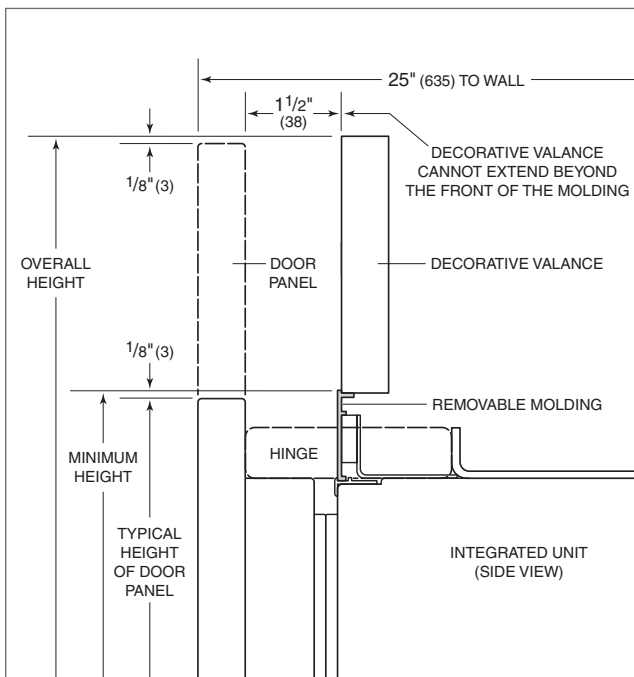

UPPER VALANCE
COLUMN AND TALL MODELS

TOE KICK CLEARANCE

The toe kick clearance can vary with the height of the panel. You must keep a minimum space of 4" (102) clear below the bottom edge of the panel for proper venting. In addition, any decorative base molding must be removable and cannot exceed 4" (102) in height.

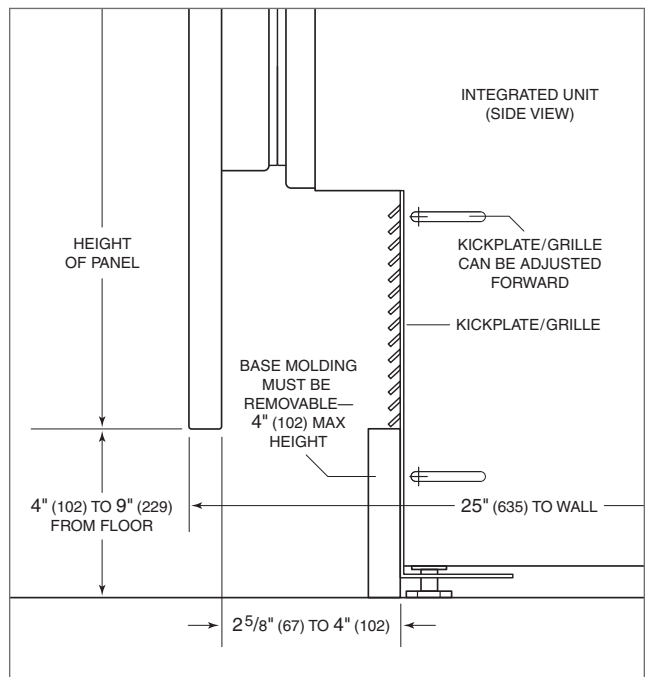

KICKPLATE/GRILLE AREA
ALL INTEGRATED MODELS

Cabinetry Applications

Integrated refrigeration is compatible with virtually any style and look of cabinetry. These models can be used with framed as well as frameless cabinetry. Because of the precise application and the look you may want to achieve, keep the following considerations in mind:

The thickness of the front panels can vary. A minimum 5/8" (16) thick panel is required, but the thickness can be increased provided the panel weight limit is not exceeded.

IMPORTANT NOTE: The depth of each integrated model is 24" (610) from the front of the unit to its back. You must allow for the thickness of the panel you are applying when planning for the finished rough opening depth if you want the front panel to be flush with surrounding cabinetry. You may have to move the unit back into drywall or bring the cabinets forward to achieve a flush fit.

Reveals between panels can vary. A reveal of 1/8" (3) is typical, but reveals can be increased to up to 1/4" (6).

⚠ CAUTION
As reveals between cabinetry and the unit decrease, the potential exists for severe finger pinching while the door is closing.

⚠ CAUTION
When 3/4" (19) or thicker panels are used with a reveal of less than 1/4" (6), door panels may cause damage to the unit when the door is opened to the maximum 105°. Use the built-in 90° door stop.

IMPORTANT NOTE: The inside edges of the rough opening as well as the sides and a portion of the backside of the decorative panels will need to be finished, as they will be exposed when the doors are open.

D-style handles are recommended. For the cabinet door, handles must be located near the edge of the panel opposite the hinge, centered top to bottom. Locate handles in the top center area of the drawer panels.

Illustrations on the following pages show typical applications of frameless and framed cabinetry. Also refer to the full-scale illustration at the end of this section for specifics on door openings.

Panel Requirements	
COLUMN MODELS	MAX WEIGHT
Door Panel	65 lbs (29 kg)
TALL AND DRAWER MODELS	MAX WEIGHT
27" (686) Door Panel	40 lbs (18 kg)
27" (686) Drawer Panel	12 lbs (5 kg)
36" (914) Door Panel	53 lbs (24 kg)
36" (914) Drawer Panel	16 lbs (7 kg)
PANEL THICKNESS	MINIMUM
All Panels	5/8" (16)

Cabinetry Applications

The illustrations below show typical applications of framed and frameless cabinetry. Refer to the full-scale templates at the end of this section for specifics on door openings.

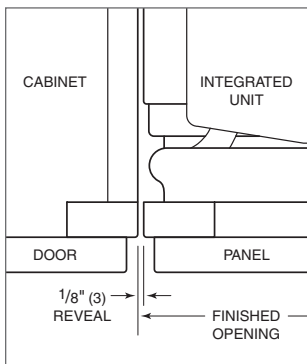

Framed — full overlay.

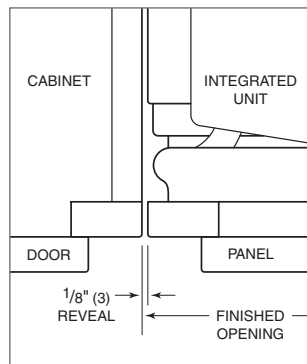

Framed — standard overlay.

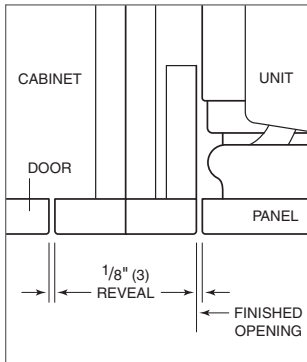

Framed — beaded inset.

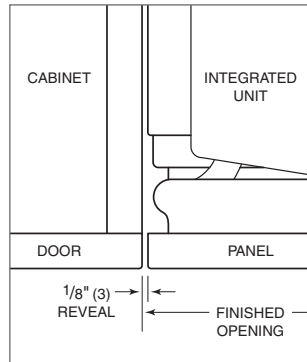

Frameless cabinetry.

Dual Installations

Two integrated units may be placed side by side in a dual installation. Depending on the models specified, opening widths will be 54" (1372), 63" (1600) or 72" (1829). Panel width dimensions will vary slightly from single installations. Refer to the chart below for typical panel dimensions. The dimensions are based on a 1/8" (3) reveal. A reveal of up to 1/4" (6) is possible with adjustments to panel dimensions.

Typical Panel Dimensions		
COLUMN MODELS	W	H
Door	26 ¹³ / ₁₆ " (681)	76 ⁷ / ₈ " (1953)
27" (686) MODELS	W	H
Door	26 ¹³ / ₁₆ " (681)	45 ³ / ₈ " (1153)
Top Drawer	26 ¹³ / ₁₆ " (681)	13 ⁹ / ₁₆ " (345)
Bottom Drawer	26 ¹³ / ₁₆ " (681)	16 ¹¹ / ₁₆ " (424)
36" (914) MODELS	W	H
Door	35 ¹³ / ₁₆ " (910)	45 ³ / ₈ " (1153)
Top Drawer	35 ¹³ / ₁₆ " (910)	13 ⁹ / ₁₆ " (345)
Bottom Drawer	35 ¹³ / ₁₆ " (910)	16 ¹¹ / ₁₆ " (424)

A dual installation kit is required for installations with 2" (51) or less space between the units. Dual installation kits are available through your authorized Sub-Zero dealer.

IMPORTANT NOTE: If a 27" (686) unit is installed next to a 36" (914) tall unit, the decorative front panels will align, however, the face frames will not. This is only apparent when both doors are open at the same time. Due to a more robust hinge on 36" (914) units, the face frame was reconfigured to maintain a consistent overall panel height. Refer to the illustration below.

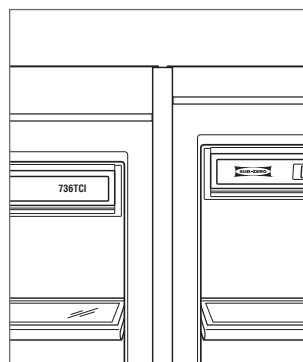

Face frame alignment.

Accessories

These optional accessories are available through your authorized Sub-Zero dealer. For local dealer information, visit the find a showroom section of our website, subzero.com.

- Stainless steel front panels with handles.
- Tubular and pro handles to match the style of Wolf ovens and ranges.
- Crisper drawer with shelf assembly, deli drawer with shelf and crisper cover with lid for certain models.
- Dual installation kit.
- Harness kit for Star-K compliance.

STANDARD HANDLE LENGTHS

Refer to the chart below for standard lengths of tubular and pro handles used on integrated models.

Standard Handle Lengths		
COLUMNS		DOOR
Tubular Handle		41 ⁷ / ₁₆ " (1053)
Pro Handle		39 ¹ / ₂ " (1003)
Stud Spacing		38 ³ / ₈ " (975)
27" (686) MODELS	DOOR	DRAWER
Tubular Handle	41 ⁷ / ₁₆ " (1053)	23" (584)
Pro Handle	39 ¹ / ₂ " (1003)	21" (533)
Stud Spacing	38 ³ / ₈ " (975)	19 ³ / ₄ " (502)
36" (914) MODELS	DOOR	DRAWER
Tubular Handle	41 ⁷ / ₁₆ " (1053)	32" (813)
Pro Handle	39 ¹ / ₂ " (1003)	30" (762)
Stud Spacing	38 ³ / ₈ " (975)	28 ³ / ₄ " (730)

Maximum Door Opening

FULL-SCALE TEMPLATE

If the panel is thicker than 3/4" (19), use the built-in 90° door stop to prevent damage to the panel and face frame at the maximum door opening.

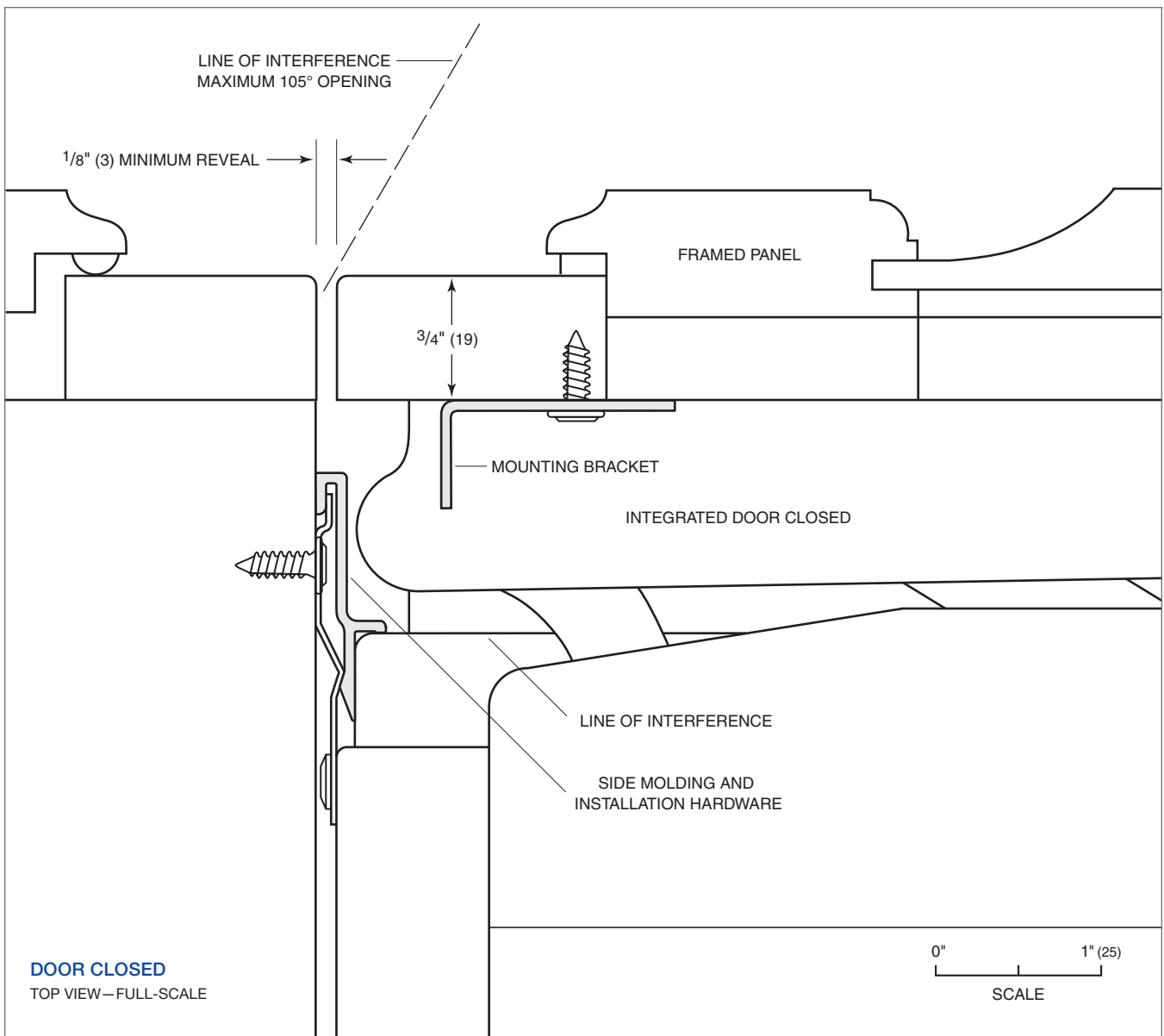
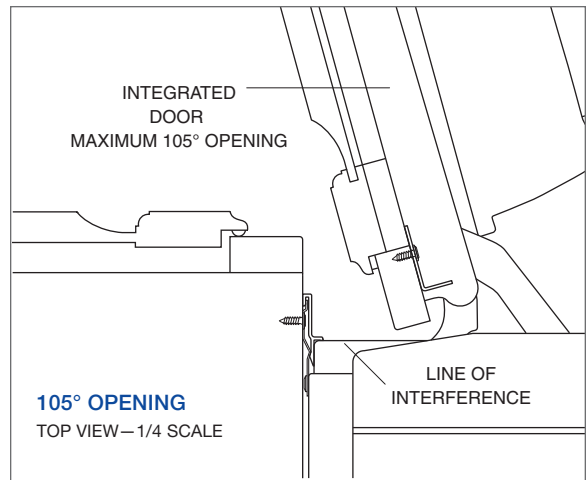



MODEL WS-30

Wine Storage. Wine finds a well-deserved place of honor in a Sub-Zero wine storage unit. Every detail is designed to ensure better wine preservation. Cherrywood-faced shelves, soft lighting, custom cabinetry if desired—Sub-Zero helps make a wine collection an element of beauty in the home.

WINE STORAGE MODELS

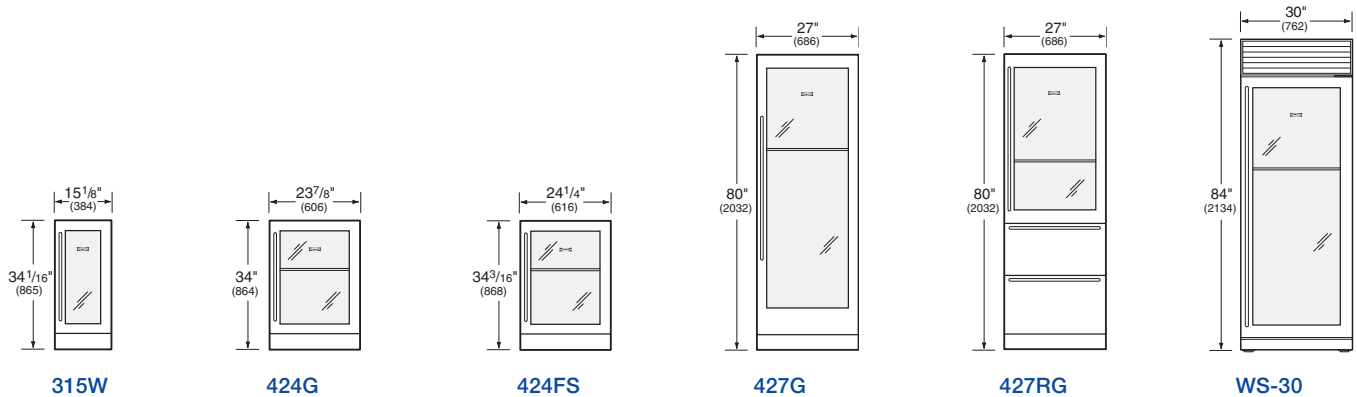

KEY FEATURES

- Integrated, overlay, flush inset and stainless steel design options.
- Full-view glass door standard on all models.
- Freestanding model 424FS does not require panels or surrounding cabinetry.
- Discreet interior lighting with illuminated display shelf.
- Two independent storage zones maintain temperature, humidity and UV protection.
- Cherrywood shelf fronts display the wine beautifully.
- Rust-proof metal shelves accommodate 750 ml bottles, half-bottles and magnums.

Overall Dimensions

UNDERCOUNTER WINE STORAGE

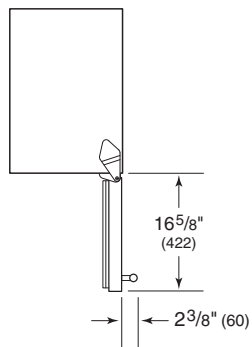
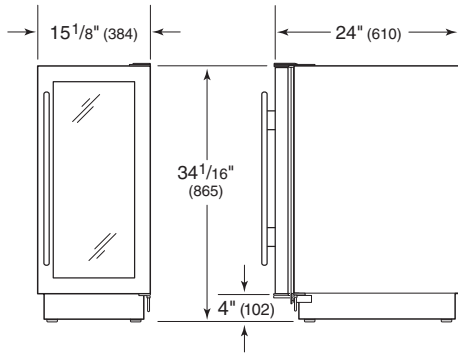

MODEL 315W

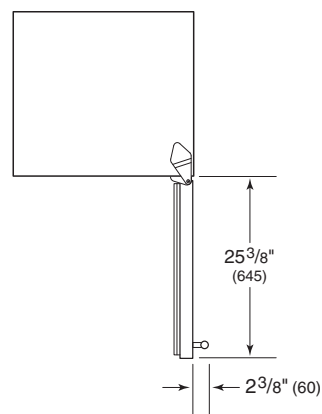
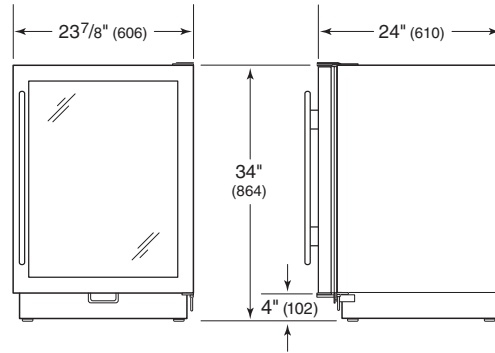

MODEL 424G

Overall dimensions are based on stainless steel panels and handles.

Overall Dimensions

FULL-SIZE WINE STORAGE

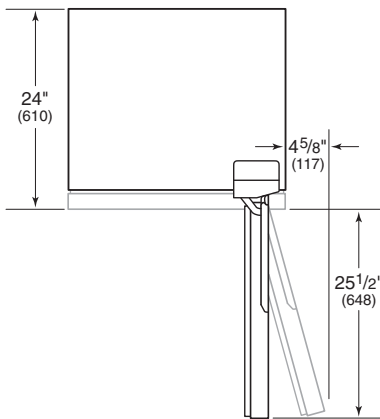
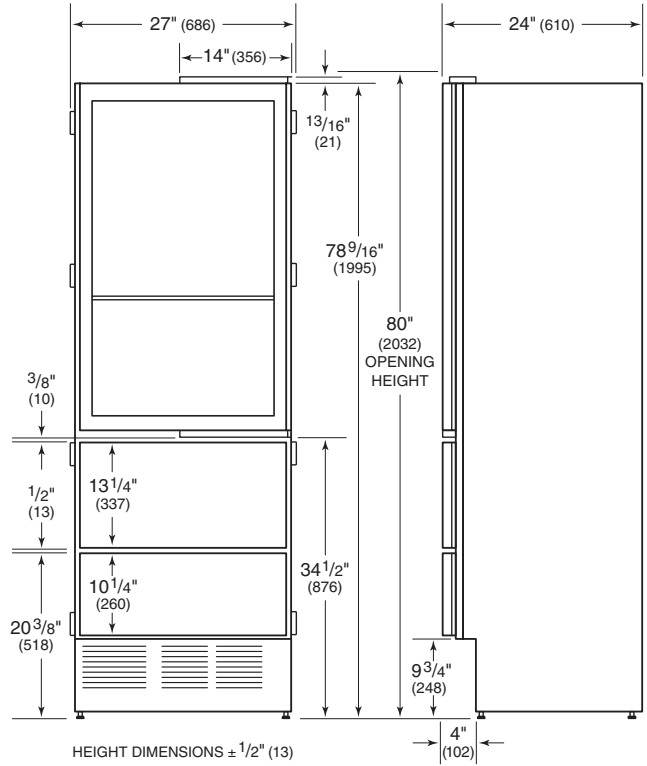
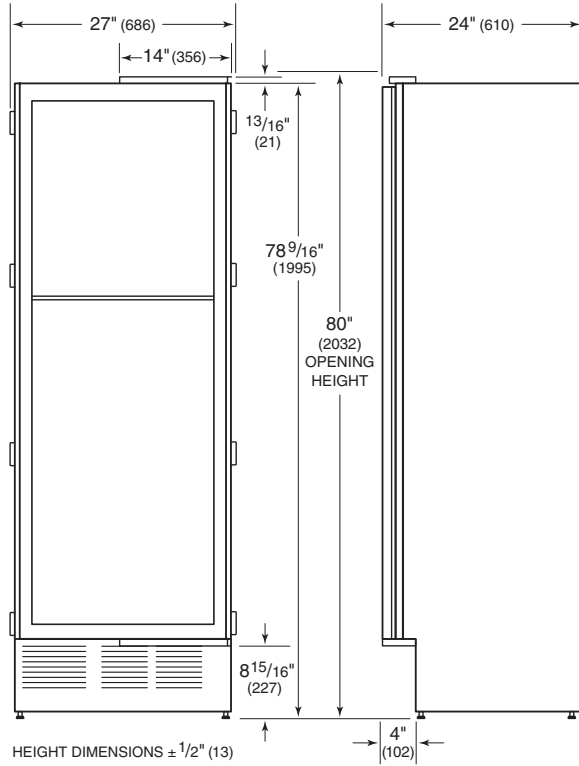

DIMENSIONS WILL VARY WITH PANEL THICKNESS

MODEL 427G

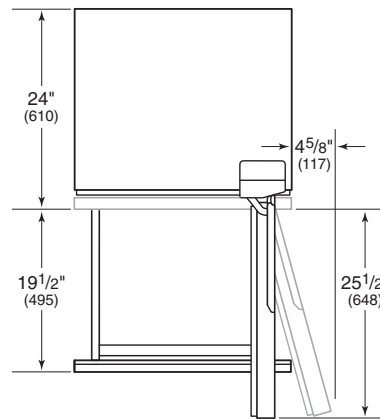

DIMENSIONS WILL VARY WITH PANEL THICKNESS

MODEL 427RG

WITH REFRIGERATOR DRAWERS

Overall dimensions do not include panels or handles.

Overall Dimensions

FULL-SIZE WINE STORAGE

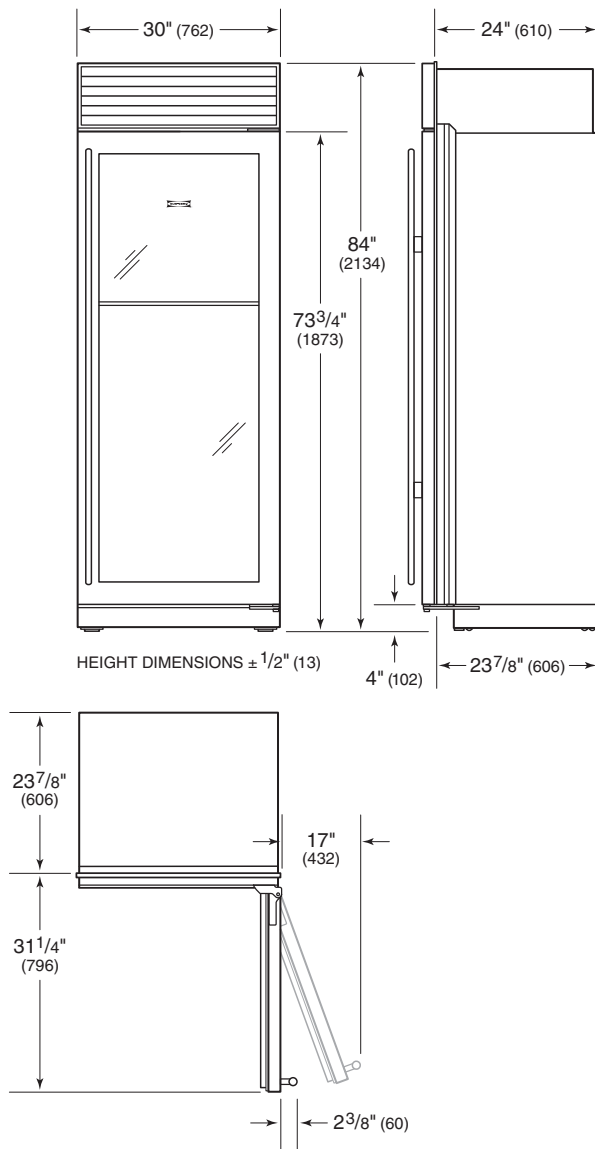

MODEL WS-30

Overall dimensions are based on the stainless steel model. For flush inset applications, add 1/2" (13) to door clearance dimensions.

Capacity and Weight

Storage Capacity	Bottles (750 ml)	R cu ft (L)
315W	26	
424G	46	
427G	132	
427RG	78	5.3 (150)
WS-30	147	

Shipping Weight	lbs (kg)
315W	118 (54)
424G	195 (88)
424FS	220 (100)
427G	395 (179)
427RG	410 (186)
WS-30	445 (202)

Opening Dimensions

UNDERCOUNTER WINE STORAGE

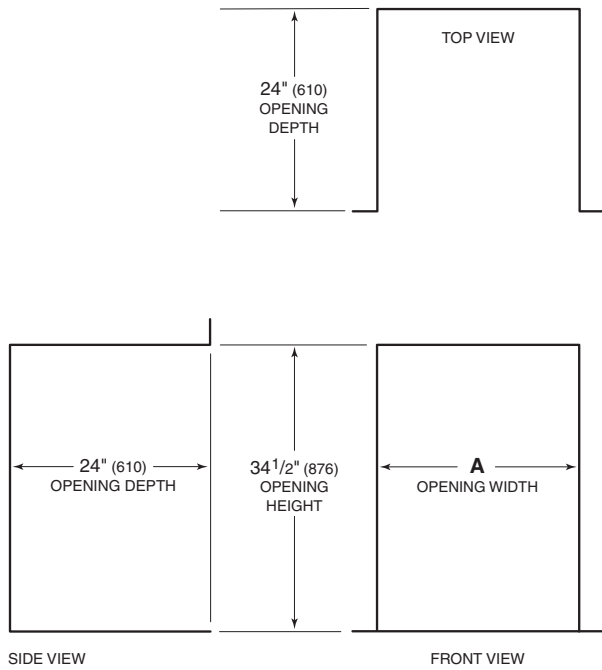

MODELS 315W AND 424G

Opening Width	A
315W	15 1/4" (387)
424G	24" (610)

FULL-SIZE WINE STORAGE

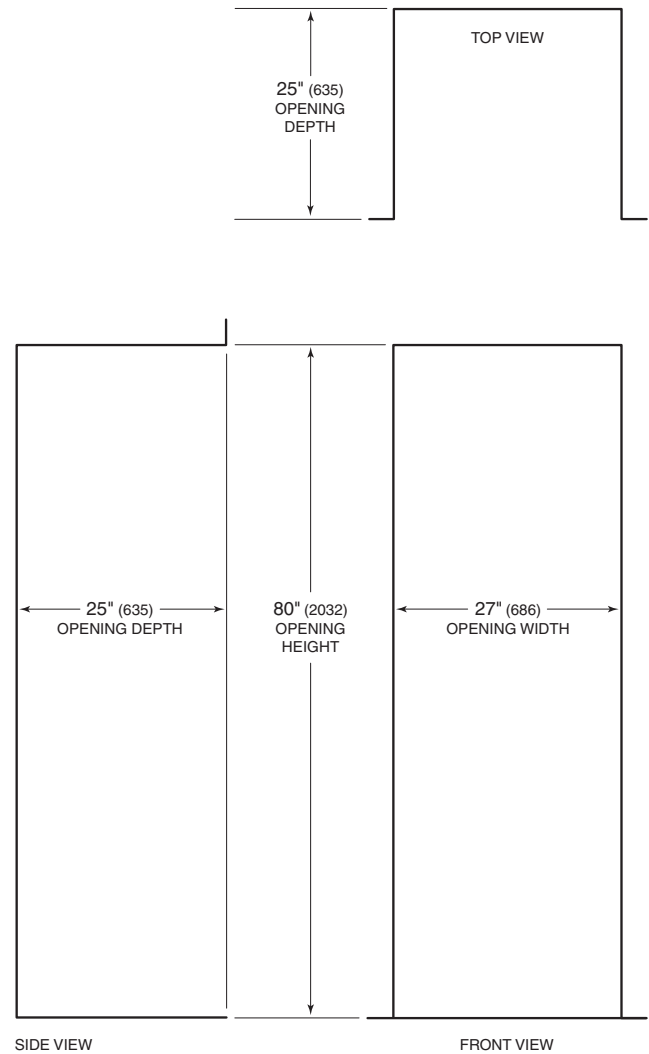

MODELS 427G AND 427RG

IMPORTANT NOTE: The depth of each integrated model is 24" (610) from the front of the unit to its back. Your design may necessitate moving the unit back or cabinets forward to achieve a flush fit. This will require a minimum rough opening depth of 25" (635).

Opening Dimensions

FULL-SIZE WINE STORAGE

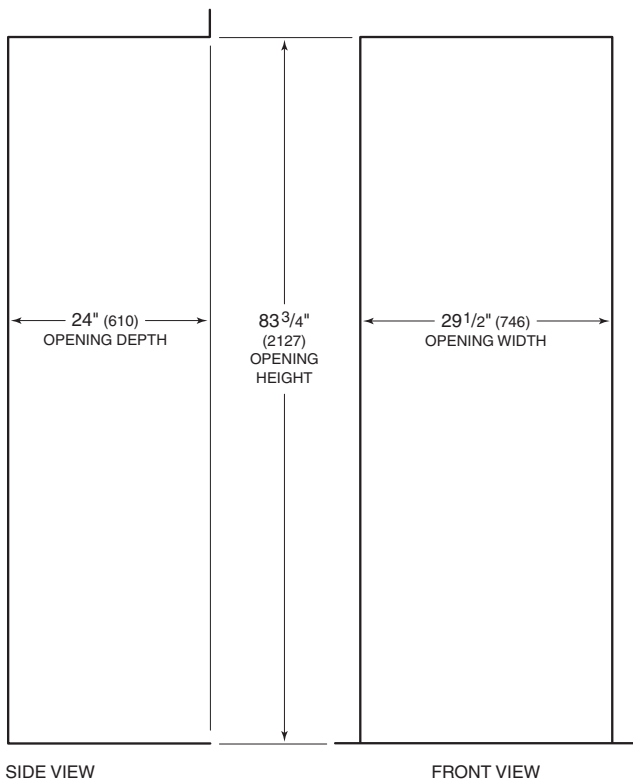
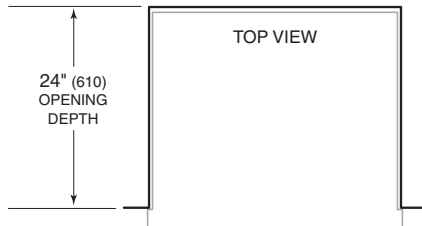

MODEL WS-30

Planning Information

All wine storage models must be installed so that the door can open a minimum of 90° or you will have problems pulling the wine shelves out. For corner installations, you need to allow for a minimum 3" (76) filler so the door can open to 90°. If you are using larger-handle hardware, you will also need to take that into account. Refer to door clearance specifications.

For a maximum 90° door opening, use the door stop built into the hinge system of model 427G. A 90° door stop is shipped with model WS-30.

If you will be connecting the unit to a home security system, you must allow a minimum of 36" (914) of the system's wiring to be routed in the electrical area designated for your model.

Planning Information

DUAL INSTALLATIONS

If you are installing a wine storage unit next to an existing Sub-Zero unit, you may have to allow for a filler strip.

If you are installing a model 427G or 427RG next to an existing integrated unit, with 2" (51) or less between the units, an optional heater kit will need to be installed to prevent moisture from forming between the units. These optional heater kits are available through your authorized Sub-Zero dealer. For local dealer information, visit the find a showroom section of our website, subzero.com.

ELECTRICAL REQUIREMENTS

The electrical supply should be located within the shaded area shown in the illustration for your specific model.

Follow the National Electrical Code and local codes and ordinances when installing the receptacle. A separate circuit, servicing only this appliance, is required. A ground fault circuit interrupter (GFCI) is not recommended and may cause interruption of operation.

Electrical Requirements	
Power Supply	115 V AC, 60 Hz
Circuit Breaker	15 amp
Receptacle	3-prong grounding-type

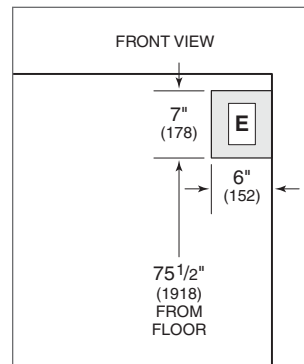

Model WS-30.

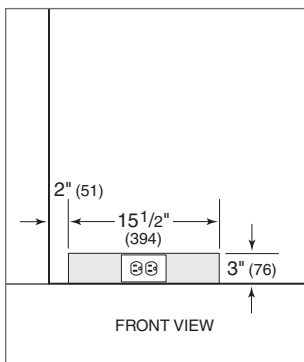

Models 315W and 424G.

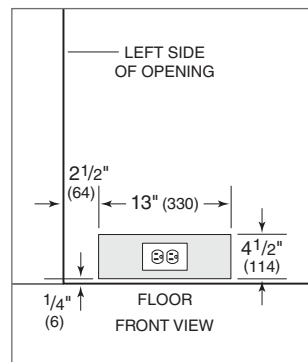

Models 427G and 427RG.

Door Panels

Unless you are installing a stainless steel model, you will need to provide a frame for the glass door. If you order a stainless steel unit, models 315W, 424G, 424FS and WS-30 will be shipped with their panels and hardware installed. For models 427G and 427RG, optional stainless steel panels or custom panels will need to be installed.

The glass door is designed to be exposed to room air circulation. Decorative overlays on the glass should be kept to a minimum. Also, rails and stiles can be increased in size but should not exceed the cabinet manufacturers' standard width and cannot exceed the overall door panel dimensions listed in the charts.

The back sides of rails and stiles that will be visible through the glass door will need to be finished. Also, the inside edges of the frames must be finished to match the front surface.

FREESTANDING MODEL 424FS

Model 424FS does not require any panels or surrounding cabinetry. It has a beautiful stainless steel exterior that is designed to be used in a freestanding application.

Overlay Panels

MODELS 315W AND 424G

The overlay panel applied to models 315W and 424G should not be confused with the built-in overlay panel application. The overlay panel will consist of just a frame and would be either the $\frac{5}{8}$ " (16) or $\frac{3}{4}$ " (19) thick panel you may be using. It is affixed directly to the door itself with screws through a series of predrilled holes in the door frame. A backer and spacer panel is not required.

Model 315W and 424G can be installed flush with surrounding cabinetry. Depending on the thickness of the overlay door panel, it may be necessary to install the unit so that it extends $\frac{1}{4}$ " (6) beyond the front surface of surrounding cabinetry. This will prevent interference between the door panel and adjoining cabinetry at the maximum 145° door swing. Refer to the full-scale template at the end of this section.

Overlay Panels		
PANEL DIMENSIONS	W	H
315W	15" (381)	30 ¹ / ₁₆ " (764)
424G	23 ³ / ₄ " (603)	30 ¹ / ₁₆ " (764)
MIN WIDTH		
Stiles and Rails	2 ¹ / ₄ " (57)	
MAX PANEL WEIGHT		
Door Frame (315W)	10 lbs (5 kg)	
Door Frame (424G)	10 lbs (5 kg)	
MIN PANEL THICKNESS		
All Panels	$\frac{5}{8}$ " (16)	

Integrated Panels

MODELS 427G AND 427RG

The integrated full panels or frame panels for glass doors for these models will follow some of the identical planning processes used with the integrated line. The installation of the door panels is completely different, however. Rather than using the mounting hardware we used with the integrated line, door panels for both models 427G and 427RG will be applied with screws applied through our door.

The drawer panels for the model 427RG will be applied using the integrated technique of mounting brackets.

IMPORTANT NOTE: The depth of models 427G and 427RG is 24" (610) from the front of the unit to its back. You must allow for the thickness of the panel you are applying when planning for the finished rough opening depth if you want the front panel to be flush with surrounding cabinetry. You may have to move the unit back into the drywall or bring the cabinets forward. Refer to the integrated section.

Panel dimensions listed in the chart assume the models finish off at 80" (2032) in height overall and have a 4" (102) toe kick for the model 427G. If you finish off at 84" (2134), for instance, you must add an additional 4" (102) to the finished height of the panel and 4" (102) to the top rail. Likewise, if you allow for a 6" (152) toe kick for the model 427G, you must subtract 2" (51) from the bottom rail.

The height of the door panel for models 427G and 427RG can extend beyond the typical panel height, provided you do not exceed the panel weight limit. Refer to specifications on page 59 of the integrated section.

The toe kick area on model 427G cannot be larger than 6" (152), and on model 427RG, no larger than 9" (229). The toe kick area for either model cannot be less than 4" (102).

If you are installing an optional lock kit on models 427G or 427RG, you may have to order door panels that exceed the 80" (2032) finished height. Consult the lock kit installation instructions and see if your panels will allow for an adequate installation. These instructions are available on our website, subzero.com.

Integrated Panels

	W	H
427G		
Door	26 ³ / ₄ " (679)	75 ⁷ / ₈ " (1927)
427RG		
Door	26 ³ / ₄ " (679)	45 ³ / ₈ " (1153)
Top Drawer	26 ³ / ₄ " (679)	13 ⁹ / ₁₆ " (345)
Bottom Drawer	26 ³ / ₄ " (679)	16 ¹¹ / ₁₆ " (424)

Panel Requirements

MIN WIDTH	
Stiles	2 ¹ / ₄ " (57)
Top Rail	3 ³ / ₄ " (95)
Bottom Rail (427G)	8" (203)
Bottom Rail (427RG)	3" (76)
MAX PANEL WEIGHT	
Door Frame	20 lbs (9 kg)
Drawer Panel (427RG)	12 lbs (5 kg)
MIN PANEL THICKNESS	
All Panels	⁵ / ₈ " (16)

Model WS-30

FRAMED PANEL

If the thickness of the framed panel is less than 1/4" (6), it must be backed up with a sheet of shim material to build the total thickness to 1/4" (6). If the panel is thicker than 1/4" (6), a routed edge must be provided around the panel to ensure a proper fit. Refer to the illustration below.

Routing, recessing or an extended handle may be required on raised panels for finger clearance under the handle.

IMPORTANT NOTE: Do not cover the glass door with a solid panel. The window cut-out edges of the framed panel will need to be finished, as they will be exposed.

FRAMED PANEL SPECIFICATIONS

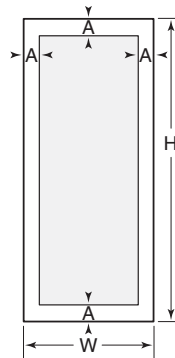

Framed Panel Requirements	
MODEL WS-30	
Max Panel Weight	75 lbs (34 kg)
Min Panel Thickness	1/4" (6)

WS-30 Framed		
DOOR	W	H
Door Panel	29 ³ / ₄ " (756)	69 ⁹ / ₁₆ " (1767)
WINDOW	W	H
Cut-Out	23 ¹ / ₂ " (597)	63 ⁵ / ₁₆ " (1608)
Location		A 3 ¹ / ₈ " (79)

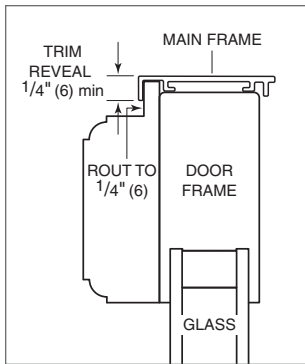

Raised framed panel.

Model WS-30

OVERLAY PANEL

Overlay model WS-30 can be used in an overlay or flush inset application. The specific application will affect panel sizes, opening dimensions and the installation.

Overlay model WS-30 will be shipped without handle hardware and with an overlay panel grille as standard equipment. Along with the door panel, you will need to provide a panel for the grille and hardware to complement your surrounding cabinetry.

The overlay design allows the decorative panel to cover the door trim for a more seamless appearance. The most common way to achieve this look is to work with three panels—the decorative overlay panel, which is typically 3/4" (19), a .10" (3) spacer panel and a 1/4" (6) backer panel. Depending on your cabinet manufacturer, this could be one panel routed for different dimensions. The illustrations below will give you a better idea of the panel construction and how it interacts with our frame. The size of the overlay panel is critical, it must fit over the door frame.

IMPORTANT NOTE: Do not cover the glass door with a solid panel. The window cut-out edges of the overlay, spacer and backer panels will need to be finished, as they will be exposed.

Overlay Panel Requirements

MODEL WS-30

Max Panel Weight	75 lbs (34 kg)
Min Panel Thickness	5/8" (16)

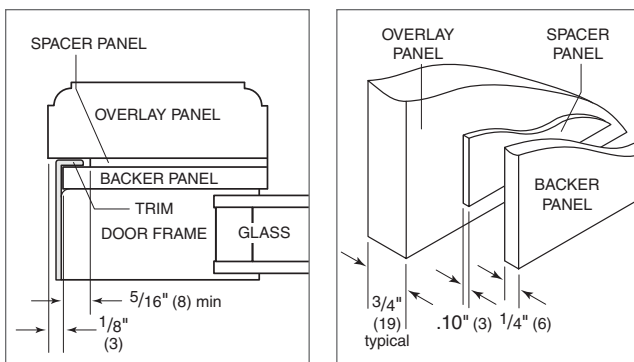

Panel assembly cross section. Panel assembly rear view.

OVERLAY PANEL SPECIFICATIONS

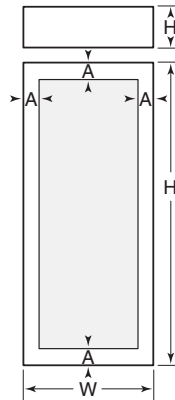

WS-30 Overlay		
DOOR	W	H
Overlay Panel	30" (762)	69 ³ / ₄ " (1772)
Spacer Panel	29 ¹ / ₈ " (740)	68 ¹⁵ / ₁₆ " (1751)
Backer Panel	29 ³ / ₄ " (756)	69 ⁹ / ₁₆ " (1767)
GRILLE	W	H
Overlay Panel	30" (762)	9 ¹ / ₄ " (235)
Spacer Panel	29 ¹ / ₈ " (740)	8 ⁵ / ₁₆ " (211)
Backer Panel	29 ³ / ₄ " (756)	8 ¹⁵ / ₁₆ " (227)
WINDOW	W	H
Cut-Out	23 ¹ / ₂ " (597)	63 ¹ / ₄ " (1607)
Location		A 3 ¹ / ₄ " (83)

Grille panel dimensions listed are for a standard 84" (2134) overall height of the unit. For an 83" (2108) overall height, subtract 1" (25) from grille panel height dimensions. For an 88" (2235) overall height, add 4" (102) to height dimensions. Width dimensions do not vary.

CAUTION

Do not exceed overlay panel dimensions, as this could cause damage to panels and the Sub-Zero unit.

Model WS-30

FLUSH INSET PANEL

Overlay model WS-30 used in a flush inset application allows the decorative panel to cover the door trim for a seamless appearance. The most common way to achieve this look is to work with three panels—the decorative flush inset panel, which is typically $\frac{3}{4}$ " (19), a .10" (3) spacer panel and a $\frac{1}{4}$ " (6) backer panel. Depending on your cabinet manufacturer, this could be one panel routed for different dimensions. The illustrations below will give you a better idea of the panel construction and how it interacts with our frame. The size of the flush inset panel is critical, it must fit over the door frame.

IMPORTANT NOTE: Do not cover the glass door with a solid panel. The inside edges of the rough opening as well as the sides and a portion of the back side of the decorative panels will need to be finished, as they will be exposed when the doors are open. The window cut-out edges of the overlay, spacer and backer panels will also need to be finished.

IMPORTANT NOTE: For flush inset panels thicker than $\frac{3}{4}$ " (19), a 90° door stop may be required to prevent interference with adjacent cabinets.

Flush Inset Panel Requirements	
MODEL WS-30	
Max Panel Weight	75 lbs (34 kg)
Min Panel Thickness	$\frac{5}{8}$ " (16)

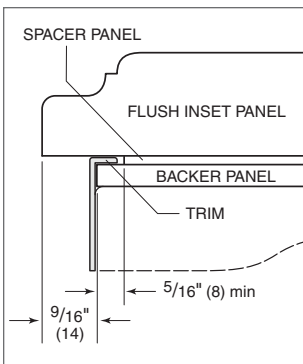

Panel assembly cross section.

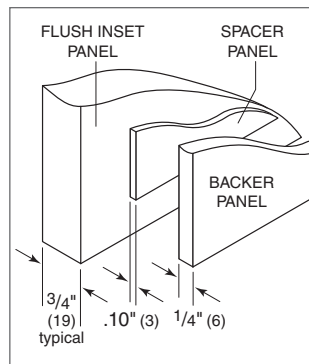

Panel assembly rear view.

FLUSH INSET PANEL SPECIFICATIONS

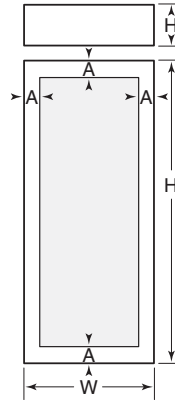

WS-30 Flush Inset		
DOOR	W	H
Flush Inset Panel	31" (787)	69 $\frac{3}{4}$ " (1772)
Spacer Panel	29 $\frac{1}{8}$ " (740)	68 $\frac{15}{16}$ " (1751)
Backer Panel	29 $\frac{3}{4}$ " (756)	69 $\frac{9}{16}$ " (1767)
GRILLE	W	H
Flush Inset Panel	31" (787)	9 $\frac{1}{4}$ " (235)
Spacer Panel	29 $\frac{1}{8}$ " (740)	8 $\frac{5}{16}$ " (211)
Backer Panel	29 $\frac{3}{4}$ " (756)	8 $\frac{15}{16}$ " (227)
WINDOW	W	H
Cut-Out	23 $\frac{1}{2}$ " (597)	62 $\frac{1}{4}$ " (1581)
Location		A 3 $\frac{3}{4}$ " (95)

Grille panel dimensions listed are for a standard 84" (2134) overall height of the unit. For an 83" (2108) overall height, subtract 1" (25) from grille panel height dimensions. For an 88" (2235) overall height, add 4" (102) to height dimensions. Width dimensions do not vary.

CAUTION
Do not exceed flush inset panel dimensions, as this could cause damage to panels and the Sub-Zero unit.

Model WS-30

FLUSH INSET PANEL

Illustrations A–D provide panel offsets and reveals for model WS-30 in a flush inset application. Refer to the chart below for reference to the illustrations.

For additional information on panel reveals, visit the specification library section of our website, subzerotrade.com.

Panel Offsets	Illus.
MODEL WS-30	
Door / Grille Sides	A
Grille Top	B
Grille Bottom / Door Top	C
Door Bottom	D

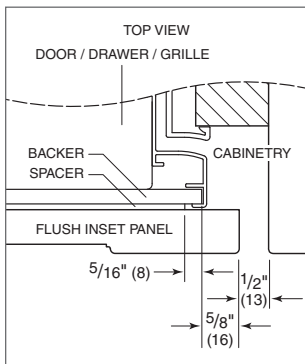

Illus. A

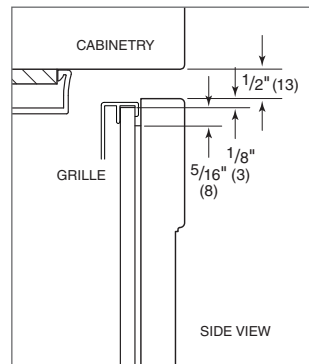

Illus. B

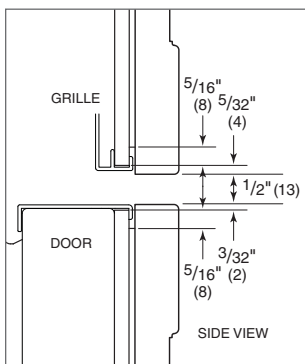

Illus. C

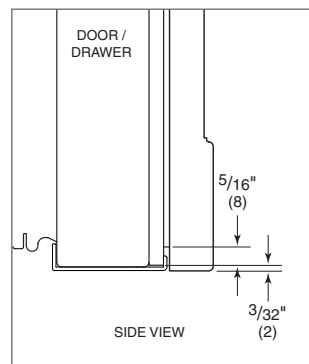

Illus. D

DUAL INSTALLATIONS

When two models WS-30 or a model WS-30 and built-in unit are installed side by side, a dual installation kit may be required. Contact your Sub-Zero dealer for the proper components and installation instructions. For questions relative to the installation, call Sub-Zero at 800-222-7820. To obtain local dealer information, visit the find a showroom section of our website, subzero.com.

DUAL STANDARD INSTALLATIONS

Two framed, overlay or stainless steel units may be placed side by side in a dual installation. Some dual standard installations will require a dual installation kit, available through your Sub-Zero dealer.

A custom filler strip can be used in between two units in a framed, overlay or stainless steel design application. It is recommended that the filler strip be at least 2" (51) wide, to prevent condensation between the units. Be sure to add the filler strip width to your rough opening width.

Dual installations without a filler strip can only be accomplished using two units with opposite hinges as shown in illustration A below. The dual installations shown in illustrations B and C require a filler strip.

IMPORTANT NOTE: For the application shown in illustration A, a dual installation accessory kit is required.

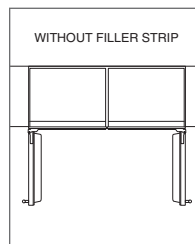

Illus. A

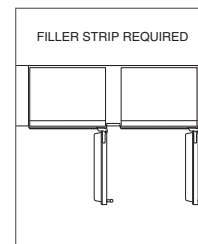

Illus. B

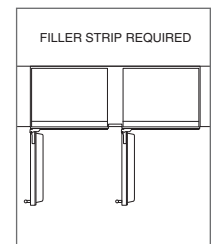

Illus. C

Model WS-30

DUAL FLUSH INSET INSTALLATIONS

Installing two models WS-30 or a model WS-30 and built-in unit side by side in a flush inset application will require adjustments to the dimensions of your finished rough opening, panel sizes and panel offsets. It will also require a dual installation kit, available through your Sub-Zero dealer.

Dual installations without a filler strip can only be accomplished using two units with opposite hinges as shown in illustration A below. The dual installations shown in illustrations B and C require a filler strip. Illustration A is the only application that will accommodate the dual wide grille.

IMPORTANT NOTE: The application shown in illustration A can only be achieved by installing dual flush inset panels. Failure to install dual flush inset panels will cause the handle side of the panels to collide when closing. In this application a dual installation accessory kit is also required.

Dual flush inset panels and dual installation kits are available through your Sub-Zero dealer. Refer to the illustration and chart for dual flush inset panel specifications.

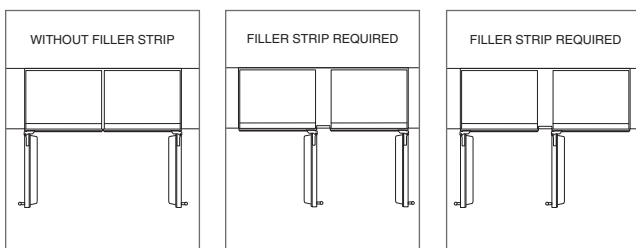

Illus. A

Illus. B

Illus. C

DUAL FLUSH INSET PANEL SPECIFICATIONS

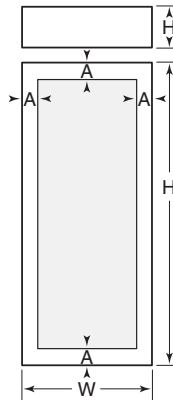

WS-30 Dual Flush Inset		
	W	H
DOOR		
Flush Inset Panel	30 ¹ / ₂ " (775)	69 ³ / ₄ " (1772)
Spacer Panel	29 ¹ / ₈ " (740)	68 ¹⁵ / ₁₆ " (1751)
Backer Panel	29 ³ / ₄ " (756)	69 ⁹ / ₁₆ " (1767)
GRILLE		
Flush Inset Panel	30 ¹ / ₂ " (775)	9 ¹ / ₄ " (235)
Spacer Panel	29 ¹ / ₈ " (740)	8 ⁵ / ₁₆ " (211)
Backer Panel	29 ³ / ₄ " (756)	8 ¹⁵ / ₁₆ " (227)
WINDOW		
Cut-Out	23" (584)	62 ¹ / ₄ " (1581)
Location		3 ³ / ₄ " (95)

Grille panel dimensions listed are for a standard 84" (2134) overall height of the unit. For an 83" (2108) overall height, subtract 1" (25) from grille panel height dimensions. For an 88" (2235) overall height, add 4" (102) to height dimensions. Width dimensions do not vary.

Model WS-30

DUAL FLUSH INSET PANELS

When installing two models WS-30 or a model WS-30 and built-in unit side by side in a flush inset application, you must decrease the width of the decorative flush inset panels by 1/2". Adjustments to the panel offsets will also need to be made. These adjustments are needed to achieve a proper fit and to ensure the panels do not collide when closing. Panel dimensions in the chart below have been adjusted to reflect the decrease in panel dimensions.

IMPORTANT NOTE: If a filler strip is not used, dual installations can only be accomplished using two units with opposite hinges.

Illustrations A–E provide panel offsets and reveals for model WS-30 in a flush inset application. Refer to the chart below for reference to the illustrations. All reveals are 1/2" (13) unless otherwise specified.

For additional information on panel reveals, visit the specification library section of our website, subzerotrade.com.

⚠ CAUTION

Do not exceed the flush inset decorative panel dimensions. Exceeding dimensions could cause damage to the panels and the Sub-Zero unit.

Panel Offsets	Illus.
MODEL WS-30	
Doors (hinge) / Grille Sides	A
Doors (handle) Sides	B
Grille Top	C
Grille Bottom / Door Top	D
Door Bottom	E

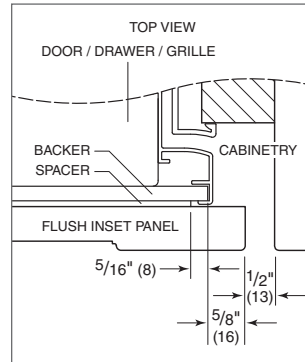

Illus. A

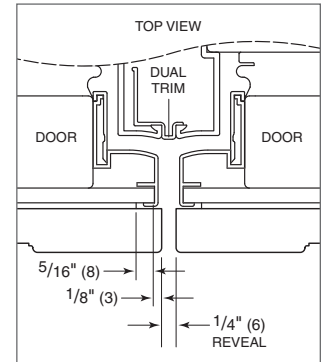

Illus. B

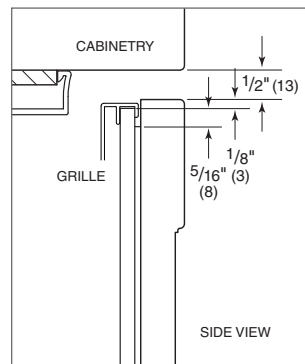

Illus. C

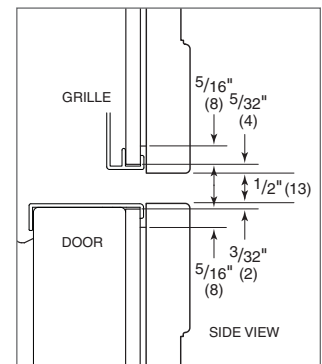

Illus. D

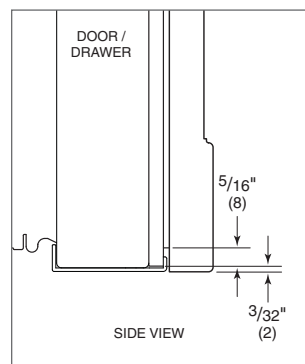

Illus. E

Side Panels

MODEL WS-30

When planning for side panels with the installation of the model WS-30, you need to be aware of the space configuration to achieve a pleasing fit. Depending on the exact panel you are using, the height of the panel may vary.

IMPORTANT NOTE: The use of side panels may change the width of your rough opening.

When installing a model WS-30 with a custom side panel, an accessory kit (7003407) is required. Stainless steel side panels are also available through your authorized Sub-Zero dealer.

The side panel will need to be a minimum of 24" (610) deep and 1/2" (13) thick. Refer to the illustrations below for side panel dimensions. Routing will be necessary so that the side panel fits flush against the side of the unit.

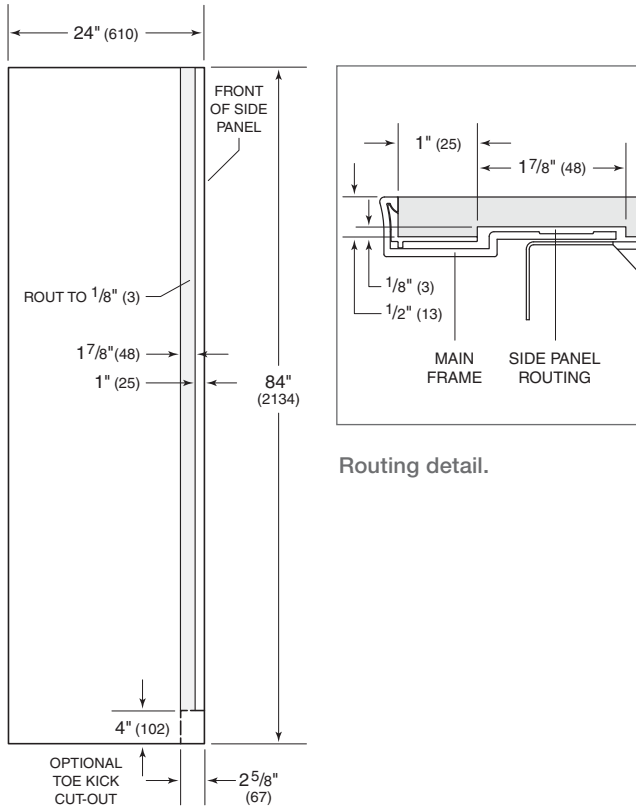

Side panel dimensions.

Handle Hardware

For overlay and integrated models, handle hardware must be provided. Optional stainless steel tubular and pro handles are available through your authorized Sub-Zero dealer.

The door frame has numerous mounting holes on each side to accommodate handle hardware. Using the pre-drilled holes to attach the handle will provide the best alignment and strength.

IMPORTANT NOTE: Refer to the full-scale template at the end of this section for a profile of the door frame and position of the glass. Do not drill through the glass.

Accessories

These optional accessories are available through your authorized Sub-Zero dealer. For local dealer information, visit the find a showroom section of our website, subzero.com.

- Front panels in stainless steel with handle options.
- Grilles for an 83" (2108) or 88" (2235) finished height for model WS-30.
- Side panels in stainless steel and white enamel for model WS-30.
- Tubular and pro handles to match the style of Wolf ovens and ranges.
- Door lock kits.
- Dual installation kits.
- Harness kit for Star-K compliance.

STANDARD HANDLE LENGTHS

Refer to the chart below for standard lengths of tubular and pro handles used on wine storage models.

Standard Handle Lengths			
315W, 424G AND 424FS		DOOR	
Tubular Handle			23" (584)
Pro Handle			21" (533)
Stud Spacing			19 ³ / ₄ " (502)
427G AND 427RG		DOOR	DRAWER
Tubular Handle	41 ⁷ / ₁₆ " (1053)		23" (584)
Pro Handle	39 ¹ / ₂ " (1003)		21" (533)
Stud Spacing	38 ³ / ₈ " (975)		19 ³ / ₄ " (502)
WS-30		DOOR	
Tubular Handle			63 ⁷ / ₈ " (1622)
Pro Handle			45 ¹ / ₈ " (1146)
Stud Spacing			43 ⁷ / ₈ " (1114)

Door Frame Profile

FULL-SCALE TEMPLATE

The full-scale template below shows an example of the door frame profile for wine storage models and the relationship to the overlay panel (rails and stiles).

Dimension	A
424G and 315W	1" (25)
427G and 427RG	7/8" (22)
WS-30	15/16" (24)

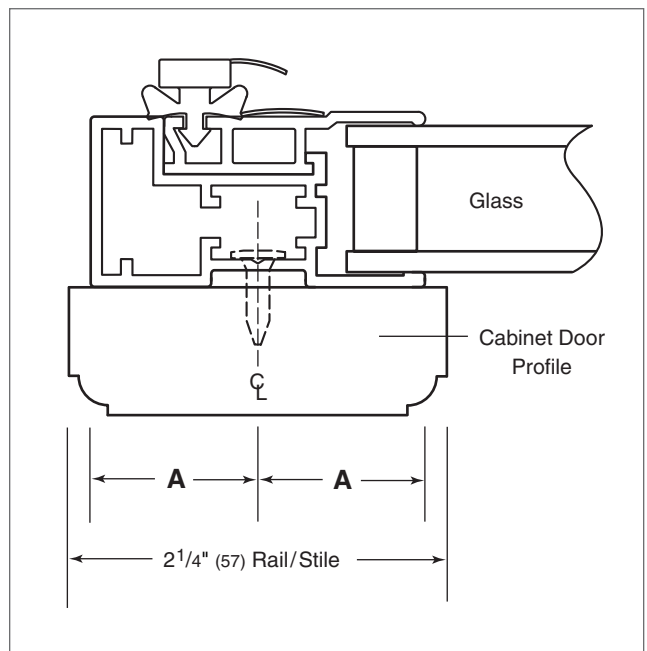

DOOR FRAME PROFILE

MODEL 424G SHOWN

Wine Shelf Wood Facing

FULL-SCALE TEMPLATE

For each model, the wine storage shelves have a natural cherrywood facing. You can replace these strips with wood more complementary to your design and surrounding cabinetry. Refer to the full-scale template below.

To remove the cherry strips, take the shelves out and remove the screws. Reverse the procedure to affix the new wood facing.

IMPORTANT NOTE: If you choose to stain or seal the wood facing, be aware that some of these substances are hazardous and will damage stored wine.

Dimension	A
315W	10 ¹⁵ / ₁₆ " (278)
424G and 424FS	19 ¹ / ₂ " (495)
427G and 427RG	20 ¹⁵ / ₁₆ " (532)
WS-30	24 ⁹ / ₁₆ " (624)

Dimensions will vary for model 315W. Refer to specifications on our website, subzero.com.

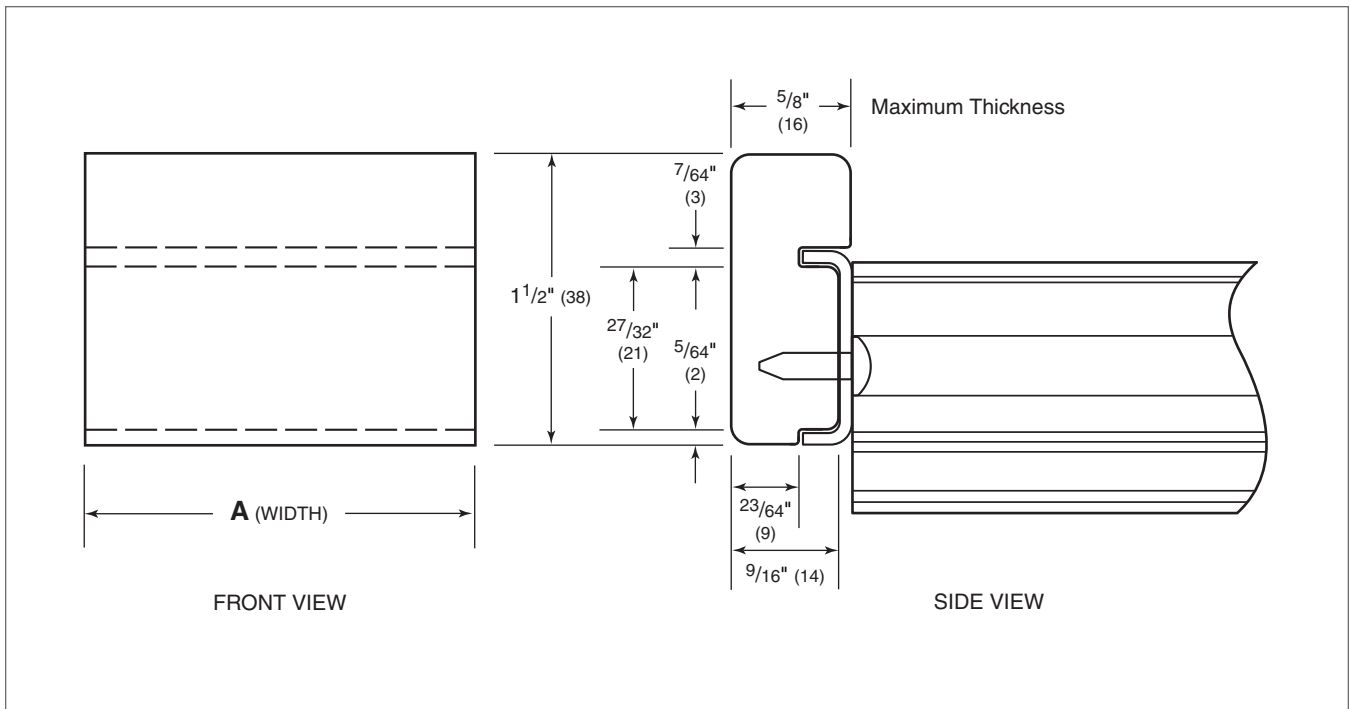

WINE SHELF WOOD FACING

WINE STORAGE MODELS

Door Clearance

FULL-SCALE TEMPLATE

Model 424G should extend a minimum of 1/4" (6) beyond the front surface of adjoining cabinetry to allow for the maximum 145° door opening. The unit can be installed flush with adjacent cabinetry, however, there is potential for interference with the panel if the door is opened past 90°.

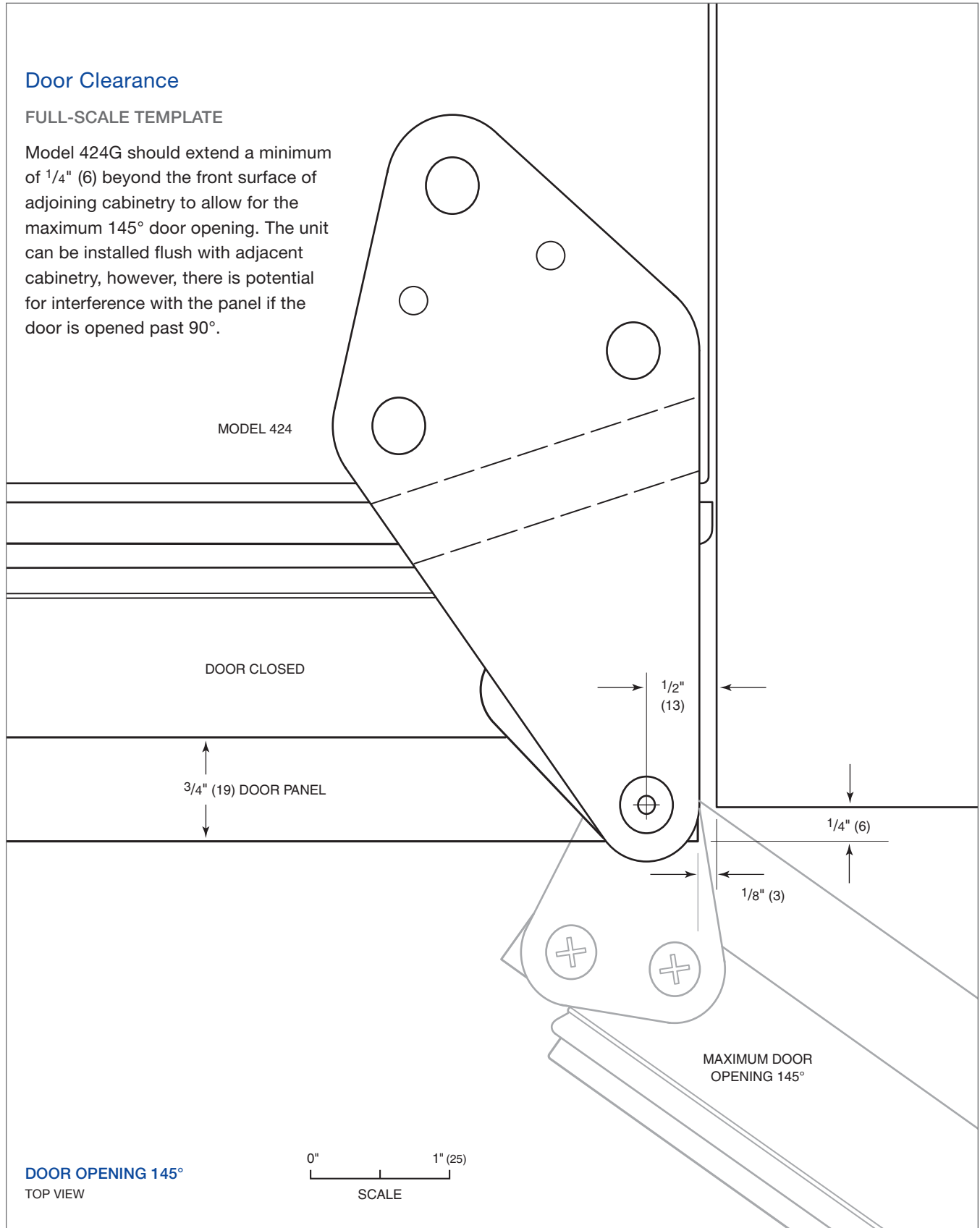



MODELS 424G (WINE) AND UC-24BG

Undercounter Refrigeration. Sub-Zero undercounter refrigeration is a helpful addition to a master suite, bar, home office or media room. In the kitchen, a high-volume ice maker is a must for entertaining. The design flexibility of these compact yet roomy units makes them all the more welcome in any room or outdoor kitchen. They're ready to be fitted with a custom cabinet panel or can be ordered with a stainless steel panel.

UNDERCOUNTER MODELS

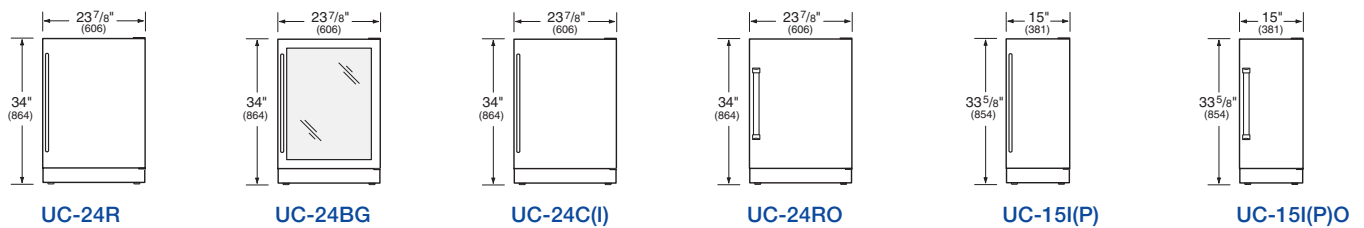

KEY FEATURES

- Overlay and stainless steel design applications.
- Handle options coordinate with handles of Wolf cooking products.
- Models UC-24RO and UC-15I(P)O are rated for outdoor use.
- Energy efficient; many models are ENERGY STAR® qualified.
- All models are Star-K certified.

Overall Dimensions

UNDERCOUNTER MODELS

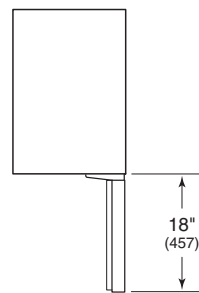
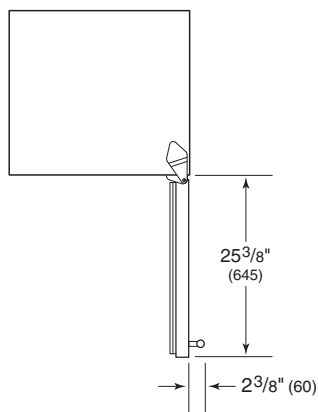
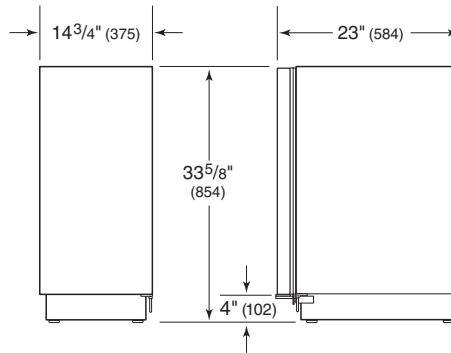
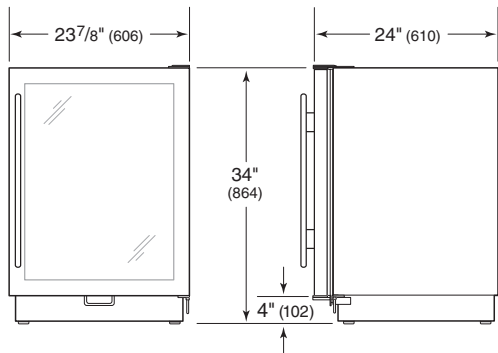

MODELS UC-24R, UC-24BG, UC-24C(I) AND UC-24RO

MODELS UC-15I(P) and UC-15I(P)O

Model UC-15I overall dimensions do not include panel or handle.

Specifications

Capacity / Weight		
INTERIOR CAPACITY	R CU FT (L)	F CU FT (L)
UC-24R, UC-24BG and UC-24RO	5.7 (161)	
UC-24C(I)	3.6 (102)	1.1 (31)
ICE STORAGE CAPACITY		LBS (KG)
UC-15I(P) and UC-15I(P)O		26 (12)
SHIPPING WEIGHT		LBS (KG)
UC-24R, UC-24BG, UC-24C(I) and UC-24RO		130 (59)
UC-15I(P) and UC-15I(P)O		100 (45)

Opening Dimensions

UNDERCOUNTER MODELS

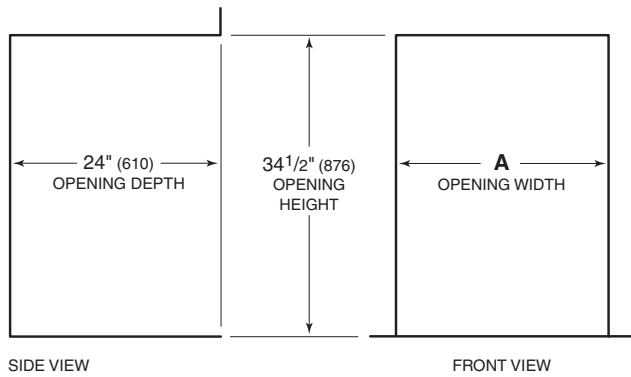
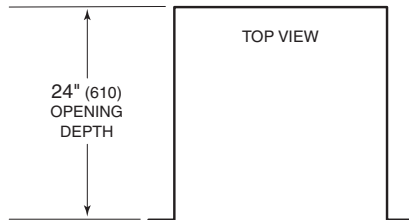

Opening Width	A
UC-24R, UC-24BG, UC-24C(I) and UC-24RO	24" (610)
UC-15I(P) and UC-15I(P)O	15 1/4" (387)

Planning Information

ELECTRICAL REQUIREMENTS

For ice maker models, the electrical supply can be located anywhere on the back wall. For all other undercounter models, locate the electrical supply within the shaded area shown in the illustration below. Follow the National Electrical Code and local codes and ordinances when installing the receptacle. A separate circuit, servicing only this appliance, is required.

IMPORTANT NOTE: Models UC-24RO and UC-15I(P)O are designed and safe for use in outdoor applications. When installed outdoors, a ground fault circuit interrupter (GFCI) is required to reduce the risk of electrical shock. A GFCI is not recommended for use with other undercounter models and may cause interruption of operation.

Electrical Requirements	
Power Supply	115 V AC, 60 Hz
Circuit Breaker	15 amp
Receptacle	3-prong grounding-type

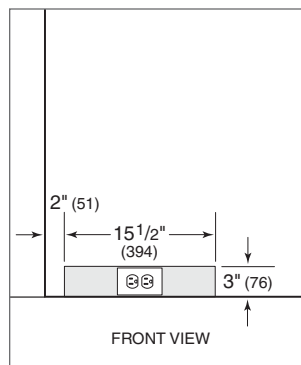

Location of electrical supply.

Planning Information

PLUMBING REQUIREMENTS

For model UC-24C(I) and the ice maker models, the water supply line should be located within the shaded area shown in the illustrations below. The water supply line should be connected to the house supply with an easily accessible shut-off valve between the supply and the unit. Do not use self-piercing valves. A saddle valve kit (4200880) is available through your authorized Sub-Zero dealer.

The ice maker operates on constant water pressure between 20 psi (1.4 bar) and 100 psi (6.9 bar).

IMPORTANT NOTE: In some cases, a reverse osmosis water filter system may not be able to maintain the minimum pressure consistently.

Plumbing Requirements	
Water Supply Line	1/4" OD copper line
Water Pressure	20–100 psi (1.4–6.9 bar)
Excess Water Line for Connection	26" (660) min

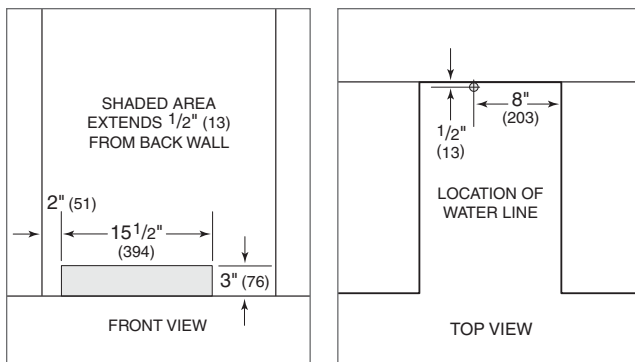

Model UC-24C(I).

Ice maker models.

Overlay Panel

MODELS UC-24R, UC-24C(I) AND UC-15I(P)

The overlay design allows for a decorative panel to cover the door trim for a seamless appearance that will complement surrounding cabinetry. You may also choose to match the handle hardware of surrounding cabinetry. Refer to the charts for panel specifications.

MODEL UC-24BG

For model UC-24BG, the overlay door panel will consist of only a frame and will affix directly to the door with screws through a series of predrilled holes.

The glass area of the door is designed to be exposed to air circulation. Decorative overlays on the glass should be kept to a minimum. Do not install a solid panel on the glass door unit: this may cause moisture to form behind the panel. Refer to the charts for panel specifications.

IMPORTANT NOTE: The width of rails and stiles can be increased but should not exceed cabinet manufacturers' standard widths or the overall panel dimensions. The back sides of rails and stiles that will be visible through the glass door will need to be finished along with the inside edges of the frame.

Panel Dimensions			
UC-24R AND UC-24C(I)	W	H	
Overlay Panel	23 ³ / ₄ " (603)	30 ¹ / ₁₆ " (764)	
UC-24BG	W	H	
Overlay Panel	23 ³ / ₄ " (603)	30 ¹ / ₁₆ " (764)	
Rails and Stiles (min)	2 ¹ / ₄ " (57)		
UC-15I(P)	W	H	
Overlay Panel	15" (381)	30 ³ / ₈ " (772)	

Panel Requirements	
MAX PANEL WEIGHT	
UC-24R and UC-24C(I)	20 lbs (9 kg)
UC-24BG	10 lbs (5 kg)
UC-15I(P)	15 lbs (7 kg)
MIN PANEL THICKNESS	
Overlay Panels	⁵ / ₈ " (16)

Drain Pump

ICE MAKER MODELS

Undercounter ice maker models can be ordered with or without a pump. Models without a drain pump will drain water from the unit by gravity. A drain must be installed. Refer to the illustrations below.

A gravity drain model may be converted to a pump model through the installation of a drain pump kit available through your authorized Sub-Zero dealer. Installation instructions are included with the drain pump kit.

The drain and inlet water tubes must be plumbed before connecting to the ice maker. For the gravity drain, all horizontal runs of drain lines must have a 1/4" (6) per 12" (305) fall. An air gap will likely be required between the ice maker and the drain receptacle. A stand pipe with a trap below it would be acceptable for the drain receptacle.

IMPORTANT NOTE: Poor drainage will cause excessive ice melting in the bin.

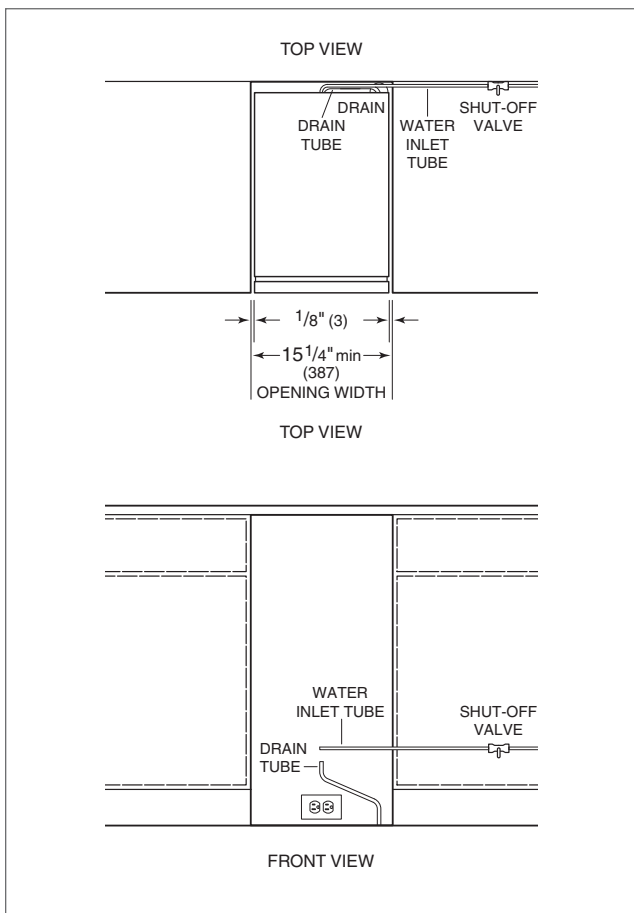

GRAVITY DRAIN
MODELS UC-15I AND UC-15IO

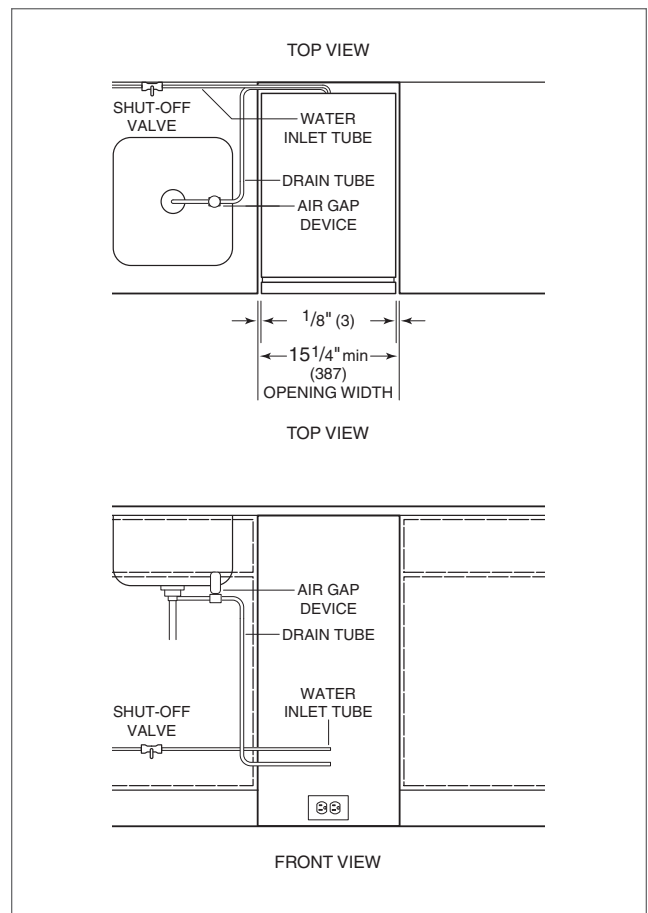

DRAIN PUMP
MODELS UC-15IP AND UC-15IPO

Door Clearance

MODELS UC-24R, UC-24BG AND UC-24C(I)

Undercounter models can be installed flush with surrounding cabinetry. Depending on the thickness of the overlay door panel, it may be necessary to install the unit so that it extends $\frac{1}{4}$ " (6) beyond the front surface of surrounding cabinetry. This will prevent interference between the door panel and adjoining cabinetry at the maximum 145° door swing. Refer to the full-scale template on page 83 of the wine storage section.

Accessories

These optional accessories are available through your authorized Sub-Zero dealer. For local dealer information, visit the find a showroom section of our website, subzero.com.

- Stainless steel front panels with handles.
- Tubular and pro handles to match the style of Wolf ovens and ranges.
- Door lock.
- Drain pump kit.

STANDARD HANDLE LENGTHS

Refer to the chart below for standard lengths of tubular and pro handles used on undercounter models.

Standard Handle Lengths	
UNDERCOUNTER MODELS	DOOR
Tubular Handle	23" (584)
Pro Handle	21" (533)
Stud Spacing	19 $\frac{3}{4}$ " (502)

Door Frame Profile

FULL-SCALE TEMPLATE

The full-scale template shows the door frame profile for model UC-24BG and the relationship to the overlay panel (rails and stiles).

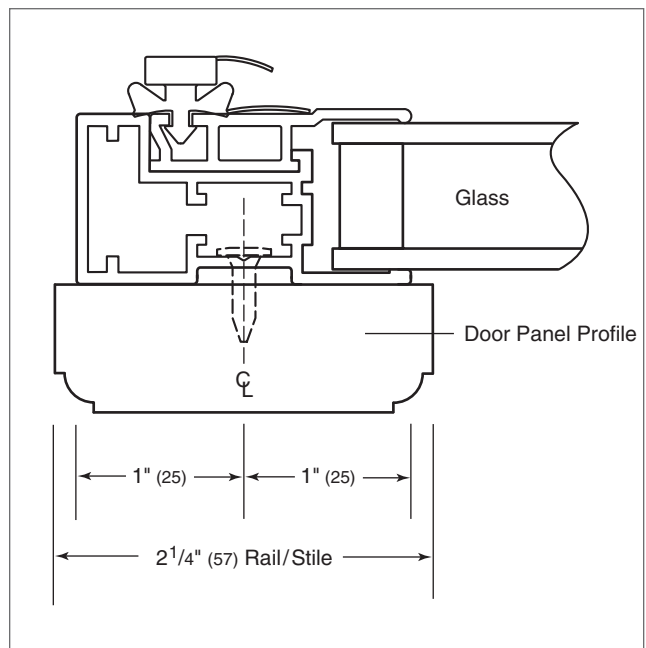

DOOR FRAME PROFILE

MODEL UC-24BG

Wine Shelf Wood Facing

FULL-SCALE TEMPLATE

For models UC-24BG and UC-24C(I), follow dimensions in the full-scale template below if you choose to replace the natural cherrywood facing of the wine shelves with wood more complementary to your design and surrounding cabinetry.

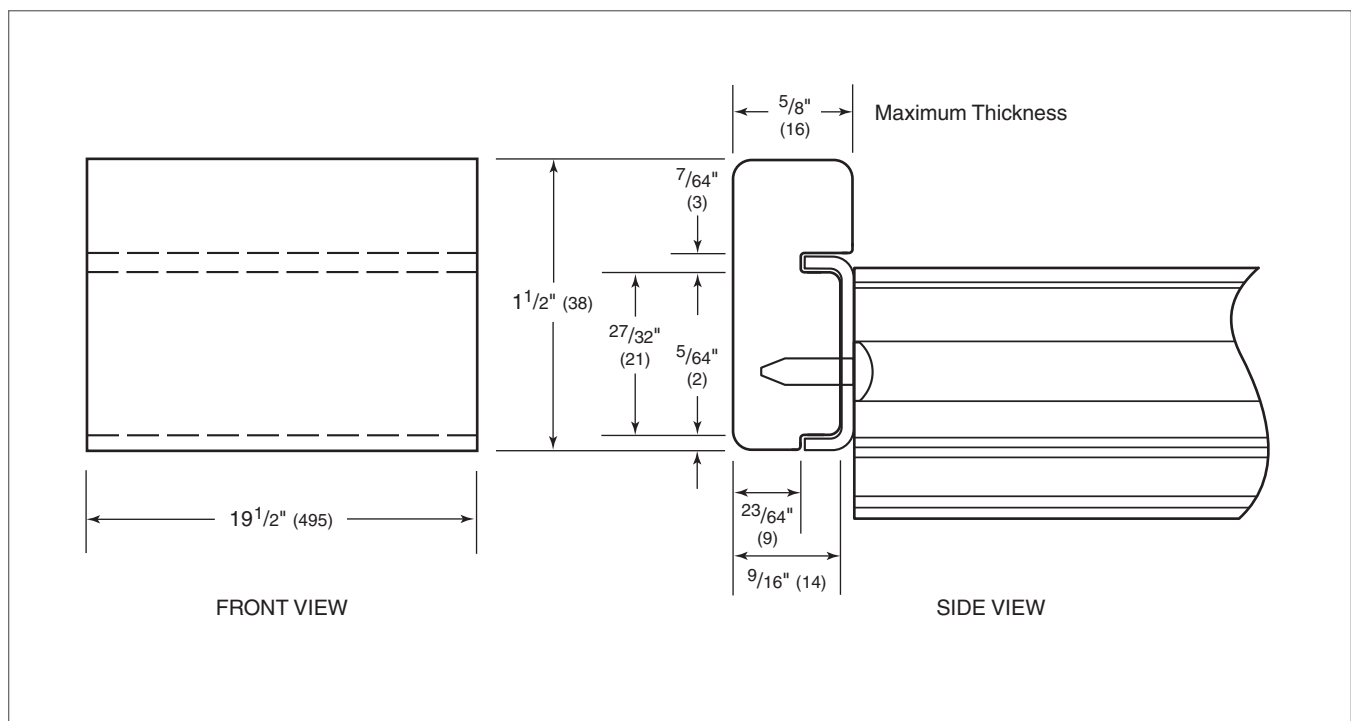

WINE SHELF WOOD FACING

MODELS UC-24BG AND UC-24C(I)

The information and images in this guide are the copyright property of Sub-Zero, Inc. Neither this guide nor any information or images contained herein may be copied or used in whole or in part without the express written permission of Sub-Zero, Inc. ©Sub-Zero, Inc. all rights reserved.

Wolf, Wolf & Design, Wolf Gourmet, W & Design and the color red as applied to knobs are registered trademarks and service marks of Wolf Appliance, Inc. Sub-Zero, Sub-Zero & Design, Dual Refrigeration, Constant Care and The Living Kitchen are registered trademarks and service marks of Sub-Zero, Inc. (collectively, the "Company Marks.") All other trademarks or registered trademarks are property of their respective owners in the United States and other countries.

Sub-Zero Products Limited Warranty

RESIDENTIAL USE ONLY

FULL FIVE YEAR SEALED SYSTEM WARRANTY LIMITED SIXTH THROUGH TWELFTH YEAR WARRANTY ON THE SEALED SYSTEM FULL TWO YEAR WARRANTY ON TOTAL PRODUCT*

FULL FIVE YEAR SEALED SYSTEM WARRANTY

For five years from the date of original installation, your Sub-Zero warranty covers all parts and labor to repair or replace any components that prove to be defective in materials or workmanship in the sealed system. The sealed system consists of the compressor, condenser, evaporator, drier and all connecting tubing.

FULL TWO YEAR WARRANTY*

For two years from the date of original installation, your Sub-Zero warranty covers all parts and labor to repair or replace any part of the product, that proves to be defective in materials or workmanship.

LIMITED SIXTH THROUGH TWELFTH YEAR SEALED SYSTEM WARRANTY

From the 6th through the 12th year from the date of original installation, your Sub-Zero warranty covers all parts that prove to be defective in materials or workmanship in the sealed system (parts only). The sealed system consists of the compressor, condenser, evaporator, drier and all connecting tubing.

TERMS APPLICABLE TO EACH WARRANTY

All service provided by Sub-Zero under the above warranty must be performed by a Sub-Zero authorized service center, unless otherwise specified by Sub-Zero. Service will be provided in the home during the normal business hours. This warranty applies only to products installed for normal residential use. Details regarding a non-residential warranty are available upon request.

The warranty applies only to products installed in any one of the fifty states of the United States, the District of Columbia or the ten provinces of Canada. This warranty does not cover any parts or labor to correct any defect caused by negligence, accident or improper use, maintenance, installation, service or repair, including but not limited to improper removal and reinstallation (whether in the unit or at a remote location) of the condensing unit.

THE REMEDIES DESCRIBED ABOVE FOR EACH WARRANTY ARE THE ONLY ONES THAT SUB-ZERO WILL PROVIDE, EITHER UNDER THESE WARRANTIES OR UNDER ANY WARRANTY ARISING BY OPERATION OF LAW. SUB-ZERO WILL NOT BE RESPONSIBLE FOR ANY CONSEQUENTIAL OR INCIDENTAL DAMAGES ARISING FROM THE BREACH OF THESE WARRANTIES OR ANY OTHER WARRANTIES, WHETHER EXPRESS, IMPLIED OR STATUTORY.

Some states do not allow the exclusion or limitation of incidental or consequential damages, so the above limitation or exclusion may not apply to you. This warranty gives you specific legal rights and you may also have other legal rights, which vary from state to state.

To receive parts and/or service and the name of the Sub-Zero authorized service center nearest you, contact Sub-Zero, Inc., P.O. Box 44848, Madison, WI 53744; check the contact & support section of our website, subzero.com or call 800-222-7820.

*Stainless steel doors, panels, product frames and interior surfaces are covered by a limited 60-day parts and labor warranty for cosmetic defects.

*Replacement water filters and air purification cartridges are not covered by the product warranty.



Sub-Zero Outdoor Products Limited Warranty

RESIDENTIAL USE ONLY

FULL FIVE YEAR SEALED SYSTEM WARRANTY FULL ONE YEAR WARRANTY ON TOTAL PRODUCT*

FULL FIVE YEAR SEALED SYSTEM WARRANTY

For five years from the date of original installation, your Sub-Zero warranty covers all parts and labor to repair or replace any components that prove to be defective in materials or workmanship in the sealed system. The sealed system consists of the compressor, condenser, evaporator, drier and all connecting tubing.

FULL ONE YEAR WARRANTY*

For one year from the date of original installation, your Sub-Zero warranty covers all parts and labor to repair or replace any part of the product which proves to be defective in materials or workmanship.

TERMS APPLICABLE TO EACH WARRANTY

All service provided by Sub-Zero under the above warranty must be performed by a Sub-Zero authorized service center, unless otherwise specified by Sub-Zero. Service will be provided in the home during the normal business hours. This warranty applies only to products installed for normal residential use. Details regarding a non-residential warranty are available upon request.

The warranty applies only to products installed in any one of the fifty states of the United States, the District of Columbia or the ten provinces of Canada. This warranty does not cover any parts or labor to correct any defect caused by negligence, accident or improper use, maintenance, installation, service or repair, including but not limited to improper removal and reinstallation (whether in the unit or at a remote location) of the condensing unit.

THE REMEDIES DESCRIBED ABOVE FOR EACH WARRANTY ARE THE ONLY ONES THAT SUB-ZERO WILL PROVIDE, EITHER UNDER THESE WARRANTIES OR UNDER ANY WARRANTY ARISING BY OPERATION OF LAW. SUB-ZERO WILL NOT BE RESPONSIBLE FOR ANY CONSEQUENTIAL OR INCIDENTAL DAMAGES ARISING FROM THE BREACH OF THESE WARRANTIES OR ANY OTHER WARRANTIES, WHETHER EXPRESS, IMPLIED OR STATUTORY.

Some states do not allow the exclusion or limitation of incidental or consequential damages, so the above limitation or exclusion may not apply to you. This warranty gives you specific legal rights and you may also have other legal rights, which vary from state to state.

To receive parts and/or service and the name of the Sub-Zero authorized service center nearest you, contact Sub-Zero, Inc., P.O. Box 44848, Madison, WI 53744; check the contact & support section of our website, subzero.com or call 800-222-7820.

*Stainless steel doors, panels, product frames and interior surfaces are covered by a limited 60-day parts and labor warranty for cosmetic defects.

*Replacement water filters are not covered by the product warranty.





SUB-ZERO, INC. P. O. BOX 44848 MADISON, WI 53744 SUBZERO.COM 800.222.7820

SZDG

6/2010