

T24UR915DS

UNDER-COUNTER DOUBLE DRAWER REFRIGERATOR

MASTERPIECE® COLLECTION HANDLE



Also Available:
 T24UR925DS – With Professional Collection Handle
 T24UR905DP – Custom Panel-Ready

FEATURES & BENEFITS

- Customizable cooling modes—Refrigerator, Pantry and Bar
- Soft Close drawers for ultra-smooth closing
- Customizable drawer organization
- Quick Chill
- LED Lighting
- Drawer mats keep items from sliding and remove for easy cleaning
- Touch electronic controls for temperature management

GENERAL PROPERTIES

Soft Close Drawers	Yes
Lighting	LED Lighting
Customizable Aluminum Dividers / Shelving	Yes
Removable Drawer Mats	Yes
Full Extension Drawers	Yes
Drawer Open Alarm	Yes
Quick Chill	Yes
Touch Electronic Controls	Yes
STAR-K Certified Sabbath Mode	Yes

CAPACITY

Total Capacity (cu. ft.)	4.4 cu. ft.
--------------------------	-------------

TEMPERATURE RANGES

Refrigerator	33°F (0.5°C) to 64°F (14.5°C)
Pre-Set Cooling Modes	Refrigerator 37°F (3°C) Pantry 44°F (6.6°C) Bar 34°F (1°C)
Quick Chill	Refrigerator 33°F (0.5°C) for approximately 24 hours

TECHNICAL DETAILS

Watts (W)	150 W
Current (A)	15 Amp
Volts (V)	115 V
Frequency (Hz)	60 Hz
Power Cord Length (in.)	60"
Plug Type	120V 3-Wire

DIMENSIONS & WEIGHT

Appliance Dimensions (H x W x D) (in.)	34 1/8" x 23 7/8" x 23 5/8"
Required Cutout Size (H x W x D) (in.)	34 1/2"–35 1/4" x 24" x 24"
Net / Gross Weight (lbs.)	138 / 149 lbs.

EFFICIENCY

ENERGY STAR® Certified	Yes
Annual Energy Consumption	269 kWh

WARRANTY

Limited, Entire Appliance, Parts and Labor on any Part of the Refrigerator that Fails Because of a Manufacturing Defect

2 Year

Limited Warranty for Sealed Refrigeration System*; Parts and Labor

3rd to 6th Year

Limited Warranty for Sealed Refrigeration System*; Parts Only

7th to 12th Year

*Height adjustable + 1/2" (13 mm) with legs fully extended

**Sealed refrigeration system includes compressor, evaporator, condenser, dryer / strainer and connection tubing

T24UR915DS

UNDER-COUNTER DOUBLE DRAWER REFRIGERATOR

MASTERPIECE® COLLECTION HANDLE



DOUBLE DRAWER REFRIGERATOR PRODUCT DIMENSIONS

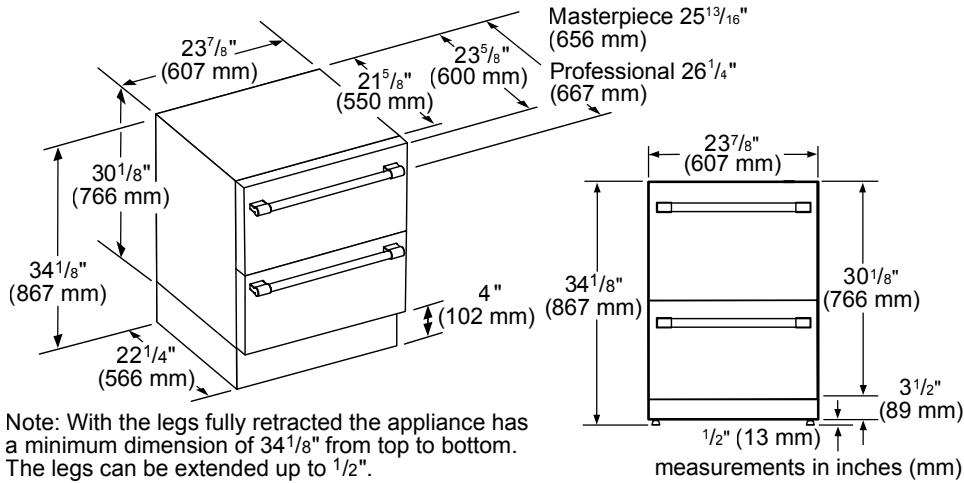

DOUBLE DRAWER REFRIGERATOR CUTOUT DIMENSIONS

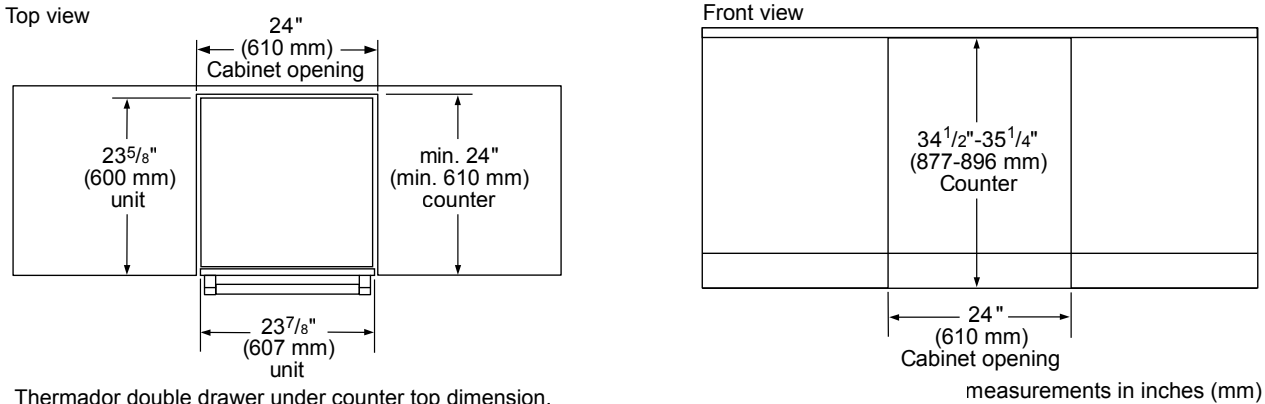

Thermador double drawer under counter top dimension. (Unit door flushed with the cutout) measurements in inches (mm)

DOUBLE DRAWER REFRIGERATOR CLEARANCE DIMENSIONS

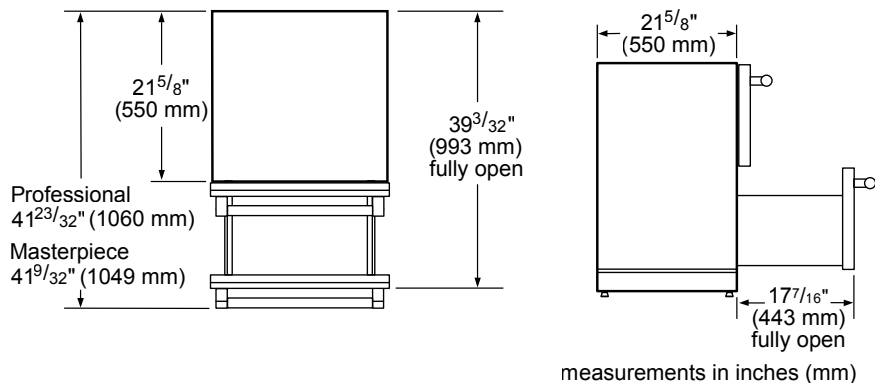

T24UR915DS

UNDER-COUNTER DOUBLE DRAWER REFRIGERATOR

MASTERPIECE® COLLECTION HANDLE



DOUBLE DRAWER REFRIGERATOR SIDE-BY-SIDE INSTALLATION

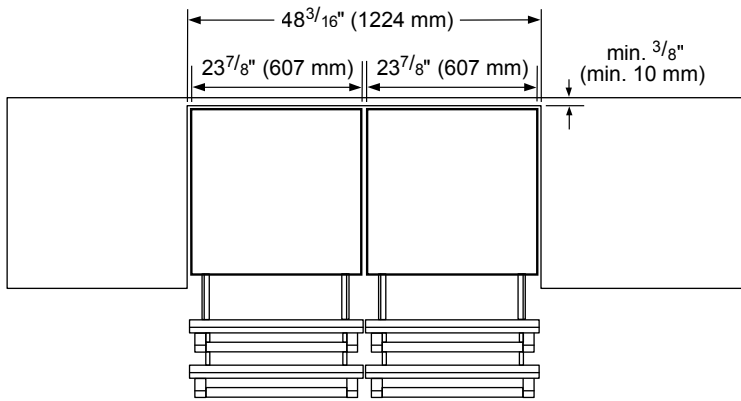

measurements in inches (mm)

DOUBLE DRAWER REFRIGERATOR CUTOUT DIMENSIONS & ELECTRICAL LOCATION

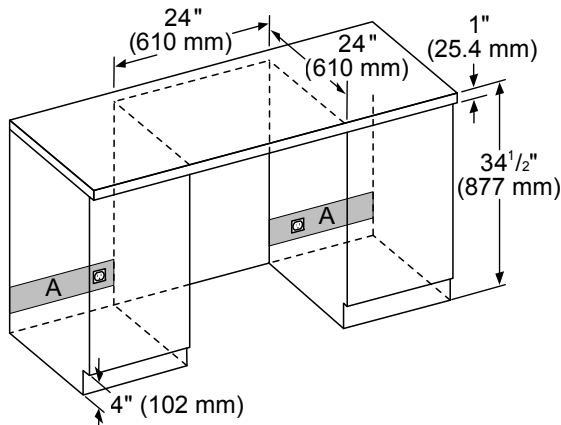

A:
Recommended area for installation connection - a 2 1/2" (63 mm) diameter hole is recommended. Location of power cord at base of the appliance.

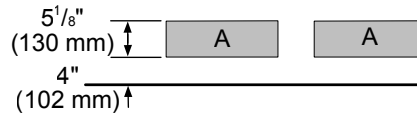

For flush installation, recommend outlet to be placed to the side of the unit and not directly behind.

measurements in inches (mm)

These warranties give you specific legal rights and you may have other rights that vary from state to state. Limited warranty from date of delivery. For complete warranty details, refer to your Use & Care manual, or ask your dealer.

Specifications are for planning purposes only. Refer to installation instructions and consult your countertop supplier prior to making counter opening. Consult with a heating and ventilation engineer for your specific ventilation requirements. For the most detailed information, refer to installation instructions accompanying product or write to Thermador indicating the model number. Specifications are correct at time of printing. Thermador reserves the right to change product specifications or design without notice. Some models are certified for use in Canada. Thermador is not responsible for products that are transported from the U.S. for use in Canada.